

IVQ in Telecommunication Systems 2730

Technician Diploma

City & 
Guilds

www.cityandguilds.com



ACCREDITED

e-skills

Publications and enquiries

City & Guilds publications are available from

Publications Sales

City & Guilds

1 Giltspur Street

London

EC1A 9DD

United Kingdom

T +44 (0)20 7294 2850

F +44 (0)20 7294 3387

General information about City & Guilds may be obtained from Customer Relations at the above address, or on 020 7294 3500, or by e-mailing **international@city-and-guilds.co.uk**

Equal opportunities

City & Guilds fully supports the principle of equal opportunities and we are committed to satisfying this principle in all our activities and published material.

Every effort has been made to ensure that the information contained in this publication is true and correct at the time of going to press. However, City & Guilds' products and services are subject to continuous development and improvement and the right is reserved to change products and services from time to time. City & Guilds cannot accept liability for loss or damage arising from the use of information in this publication.

©2003 The City and Guilds of London Institute. All rights reserved.
City & Guilds is a trademark of the City and Guilds of London Institute.

1 Giltspur Street

London

EC1A 9DD

T +44 (0)20 7294 2468

F +44 (0)20 7294 2400

www.cityandguilds.com

IVQ in Telecommunication Systems 2730

Technician Diploma



INVESTOR IN PEOPLE

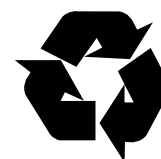

Printed on
recycled paper

[This page is intentionally blank]

Contents

05 IVQ in Telecommunication Systems 2730

05 About City & Guilds

05 About e-skills UK

05 Introduction to this programme

05 Certificate

05 Diploma

05 Advanced Diploma

05 Full Technological Diploma

06 Making entries for assessments

06 Internal candidates

06 External candidates

06 Resources

06 Assessments

06 Award number

06 Component numbers

07 Technician Diploma in Applied Telecommunication Systems

07 Technician Diploma in Telecommunication Systems Theory

07 Fixed and free dates

08 Results and certification

08 How to offer this programme

08 Subject approval

08 Examination centre approval

08 Other information

08 Designing courses of study

09 Presentation format of units

09 Practical competences

09 Knowledge requirements

09 Practical assignments

10 Entry levels

10 Progression routes and recognition

10 Useful publications

11 Syllabus

IVQ in Telecommunication Systems 2730

12 011 Fundamentals of Electronic Communication 2
01 Applied mathematics

13 011 Fundamentals of Electronic Communication 2
02 Boolean algebra, logic gates and relaxation oscillators

14 011 Fundamentals of Electronic Communication 2
03 Telecommunications systems and networks

16 011 Fundamentals of Electronic Communication 2
04 Noise

17 011 Fundamentals of Electronic Communication 2
05 Logarithms and decibels

18 011 Fundamentals of Electronic Communication 2
06 Transmission lines

19 011 Fundamentals of Electronic Communication 2
07 The basic principles of filters and radio
frequency (r.f.) oscillators

20 011 Fundamentals of Electronic Communication 2
08 Modulation

22 Assessment

23 012 Communication Systems and Digital Networks 2
01 Data communication fundamentals

24 012 Communication Systems and Digital Networks 2
02 The Open Systems Interconnection (OSI) reference model

25 012 Communication Systems and Digital Networks 2
03 Transmission Control Protocol / Internet Protocol (TCP/IP)

27 012 Communication Systems and Digital Networks 2
04 Data packets, frames and cells

29 012 Communication Systems and Digital Networks 2
05 Switching and routing

31 Assessment

32 013 Fundamentals of Electronic Communication 3
01 Stabilised power supplies

33 013 Fundamentals of Electronic Communication 3
02 Optical fibre systems

34 013 Fundamentals of Electronic Communication 3
03 Modulation

35 013 Fundamentals of Electronic Communication 3
04 Digital transmission and multiplexing

36 013 Fundamentals of Electronic Communication 3
05 Pulse modulation and Time Division Multiplex (TDM) systems

38 013 Fundamentals of Electronic Communication 3
06 Access network and digital telephone exchanges

40 Assessment

41 014 Communication Systems and Digital Networks 3
01 Structured cabling

42 014 Communication Systems and Digital Networks 3
02 Local Area Networks (LANs), Metropolitan Area Networks
(MANs) and Wide Area Networks (WANs)

43 014 Communication Systems and Digital Networks 3
03 Transmission systems

44 014 Communication Systems and Digital Networks 3
04 End systems

45 014 Communication Systems and Digital Networks 3
05 Network management

47 014 Communication Systems and Digital Networks 3
06 Internet Data Centre (IDC)

48 Assessment

49 015 Telecommunication Systems Practice 2/3

50 Practical assignments – Fundamentals of Electronic
Communication 2

53 Practical assignments – Fundamentals of Electronic
Communication 2

55 Practical assignments – Communication Systems and
Digital Networks 2

57	Practical assignments – Communication Systems and Digital Networks 2
59	Practical assignments – Communication Systems and Digital Networks 2
62	Practical assignments – Fundamentals of Electronic Communication 3
64	Practical assignments – Fundamentals of Electronic Communication 3
68	Practical assignments – Communication Systems and Digital Networks 3
70	Practical assignments – Communication Systems and Digital Networks 3
72	Practical assignment – Communication Systems and Digital Networks 3
74	Practical assignments – Communication Systems and Digital Networks 3
76	Practical assignments – Communication Systems and Digital Networks 3
78	016 Radio systems
84	Assessment
85	Practical assignments – Radio Systems Practice
88	018 Programming Principles
90	Assessment
91	Practical assignments – Programming Principals Practice
93	020 Advanced Mathematics 1
96	Assessment

97	Appendix A Acronyms and abbreviations
101	Appendix B Resource requirements
102	Diploma – resource list
103	Appendix C Practical assignments
103	Practical assignments
103	Instructor notes
103	Candidate instructions
103	Marking
103	Supervision
103	Records, results and certification
103	Visiting verifier
105	Appendix D The levels of our awards
105	Progressive structure

IVQ in Telecommunication Systems 2730

About City & Guilds

We provide assessment and certification services for schools and colleges, business and industry, trade associations and government agencies in more than 100 countries. We have over 120 years of experience in identifying training needs, developing assessment materials, carrying out assessments and training assessment staff. We award certificates to people who have shown they have mastered skills that are based on world-class standards set by industry. City & Guilds International provides a particular service to customers around the world who need high-quality assessments and certification.

About e-skills UK

e-skills UK is the industry representative body responsible for addressing the needs of IT and telecommunications employers in the UK for a world class workforce in the information age.

e-skills UK benchmarked the City & Guilds award in Telecommunication Systems against the occupational standards for the UK telecommunications industry.

In meeting these requirements we at City & Guilds also raised the standard of training design and delivery, an achievement reflected in our accreditation by e-skills UK.

Successful candidates benefit from this accreditation when they apply for jobs in the UK.

Introduction to this programme

We have designed the Technician Awards in Telecommunication Systems for those undergoing training or employed in this area of work. The programme aims to reflect the international nature of the knowledge and skills and activities needed for different countries or cultures.

We do not say the amount of time a candidate would need to carry out the programme, but we do provide advice on guided learning hours for each unit at each level. The programme has three levels.

Certificate

The certificate is an entry-level qualification that has been designed for young people who have just left school, or for anyone seeking a career change. Graduates of the programme should be able to obtain employment within the telecommunications industry at the technician level in the fields of manufacture, installation, maintenance or operation. The certificate will also provide useful underpinning knowledge for those already employed in the industry at the technician or craft level.

The certificate has been designed for a minimum of 300 guided learning hours. Candidates will be expected to study for an equivalent period of their own time, in order to achieve success.

Diploma

The diploma (about 600 guided learning hours) provides more practice involving a broader range of skills appropriate to a person who may also supervise, or who wishes to progress into higher education. Graduates of the diploma should have a well-developed knowledge of the technical and design principles of complex telecommunication systems enabling them to fulfil the role of technician/senior technician across a range of specialised disciplines.

Advanced Diploma

The advanced diploma (600 guided learning hours) takes these skills to the level appropriate to a person preparing for, or working in, first-level management. It is also appropriate for someone who wishes to receive specialised training at a high level. Graduates of the advanced diploma should have a sound knowledge of the technical design principles in one or more specialised branches of telecommunications. They will have the potential to fulfil the role of senior/chief technician with a high level of responsibility requiring the use of personal initiative and critical judgement.

We stress that these figures for guided learning hours are only a guideline. We award certificates for gaining and showing skills by whatever mode of study, and not for periods of time spent in study.

We provide certificates for all work-related areas at seven levels within our structure of awards shown in appendix D. This programme covers level 3. The standards and assessments for the certificate (level 2) and the advanced diploma (level 4) are published separately.

Full Technological Diploma

We will award the Full Technological Diploma (FTD) in Telecommunication Systems to someone who is at least 21, who has had at least two years of related work experience, and who has successfully completed the assessments for the diploma and the advanced diploma levels of this award. If candidates enter for this diploma, they must also send us a portfolio of evidence to support their application.

Making entries for assessments

Candidates can only be entered for the assessments in this subject if the approved examination centres agree. Candidates must enter through an examination centre we have approved to carry out the assessments for 2730 Technician Awards in Telecommunication Systems.

There are two ways of entering candidates for assessments.

Internal candidates

Candidates can enter for examinations if they are taking or have already finished a course at a school, college or similar training institution that has directed their preparation whether by going to a training centre, working with another institution, or by open learning methods.

External candidates

These are candidates who have not finished a programme as described above. The examination centres must receive their application for entry well before the date of the examination concerned. This allows them to act on any advice you give about assessment arrangements or any further preparation needed. External candidates must carry out practical assignments and projects if necessary, and they will need extra time and guidance to make sure that they meet all the requirements for this part of the assessment.

In this publication we use the term 'centre' to mean a school, college, place of work or other institution.

Resources

If you want to use this programme as the basis for a course, you must read this syllabus and make sure that you have the staff and equipment to carry out all parts of the programme. (See appendix B.) If there are no facilities for realistic practical work, we strongly recommend that you develop links with local industry to provide opportunities for hands-on experience.

Assessments

There is one level of Technician Diploma Award in Telecommunication Systems.

Certificate

We use a numbering system to allow entries to be made for our awards. The numbers used for this programme are as follows.

Award number

2730-02 Technician Diploma in Applied
Telecommunication Systems

Technician Diploma in
Telecommunication Systems Theory

We use award numbers to describe the subject and level of the award.

Component numbers

011 Fundamentals of Electronic Communication 2
012 Communication Systems and
Digital Networks 2
013 Fundamentals of Electronic
Communications 3
014 Communication Systems and Digital Networks 3
015 Telecommunication Systems Practice 2 / 3
016 Radio Systems
017 Radio Systems Practice
018 Programming Principles
019 Programming Principles Practice
020 Advanced Mathematics 1

This unit is an option recommended for candidates entering Higher Education.

We use component numbers to show units for which we may award a certificate of unit credit.

We use these numbers throughout this syllabus. You must use these numbers correctly if you send forms to us.

Technician Diploma in Applied Telecommunication Systems

To carry out what is needed for the Technician Diploma in Applied Telecommunication Systems, candidates must be successful in all the following assessments.

2730-02-011	Fundamentals of Electronic Communication 2 (written paper which lasts three hours)
2730-02-012	Communication Systems and Digital Networks 2 (written paper which lasts three hours)
2730-02-013	Fundamentals of Electronic Communication 3 (written paper which lasts three hours)
2730-02-014	Communication Systems and Digital Networks 3 (written paper which lasts three hours)

[2730-02-015] Telecommunication Systems Practice 2 / 3

Candidates must also be successful in one pair of the following assessments:

either

2730-02-016 Radio Systems
(written paper which lasts three hours)

[2730-02-017] Radio Systems Practice

or

2730-02-018 Programming Principles
(written paper which lasts three hours)

[2730-02-019] Programming Principles Practice
(Total five written papers)

The practical assignments are carried out during the learning programme and should be finished by the date of the written examination so you can send all the results to us.
(See appendix C.)

To receive this award candidates must carry out the following practical assignments:

- nine of 015/1, 015/2, 015/3, 015/4, 015/5, 015/6, 015/7, 015/8, 015/9, 015/10, 015/11, 015/12
- and either 017/1
- or 019/1.

(Total 10 practical assignments)

Technician Diploma in Telecommunication Systems Theory

To carry out what is needed for the Technician Diploma in Telecommunication Systems Theory, candidates must be successful in all the following assessments.

2730-02-011	Fundamentals of Electronic Communication 2 (written paper which lasts three hours)
2730-02-012	Communication Systems and Digital Networks 2 (written paper which lasts three hours)
2730-02-013	Fundamentals of Electronic Communication 3 (written paper which lasts three hours)
2730-02-014	Communication Systems and Digital Networks 3 (written paper which lasts three hours)

Candidates must also be successful in one of the following units:

2730-02-016 Radio Systems
(written paper which lasts three hours)

2730-02-018 Programming Principles
(written paper which lasts three hours)
(Total five written papers)

There are no practical assignments for this award.

We provide assessments in two ways.

a Fixed date

These are assessments that are carried out on dates and times we set. These assessments have no brackets around their numbers.

b Free date

These are assessments that are carried out at a college or other training establishment on a date or over a period that the college chooses. These assessments have brackets around their numbers.

In this programme the written assessments are fixed date. The practical assignments are free date.

You must carry out assessments according to our International Directory of Examinations and Assessments. If there are any differences between information in this publication and the current directory, the directory has the most up-to-date information.

Results and certification

Everyone who enters for our certificates, diplomas, and advanced diplomas receives a 'Notification of Candidate Results' giving details of how they performed.

If candidates successfully finish any assessment within this programme (for example, any one of the examination papers) they will receive a certificate of unit credit towards the certificate or diploma for which they are aiming. We grade course work assessments as pass or fail. We grade written assessments on the basis of fail, pass, credit or distinction. The certificate of unit credit will not mention assessments that they do not enter, which they failed or from which they were absent.

Each certificate or diploma clearly states what candidates need for full certification at the relevant level, allowing schools, colleges and employers to see whether they have met the full requirements.

If candidates successfully finish all the requirements for a full certificate or a diploma, they will automatically receive the appropriate certificate.

We will send the 'Notification of Candidate Results', certificates of unit credit, certificates, diplomas and advanced diplomas to the examination centre to be awarded to successful candidates. It is your responsibility to give the candidates the certificates. If candidates have a question about the results and certificates, they must contact you. You may then contact us if necessary.

We will also send you a results list showing how all candidates performed.

How to offer this programme

To offer this programme you must get approval from us. There are two categories of approval.

Subject approval

We give approval to offer a teaching course based on this syllabus.

Examination centre approval

We give approval to enter candidates for examinations.

To be approved by us to offer a teaching course you must send us the application form.

To enter candidates for examinations you must be approved by us as an examination centre. For this programme it is possible to act as a registered examination centre only, and accept external candidates. Approved examination centres must provide suitable facilities for taking examinations, secure places to keep the examination papers and materials, and may have an appointed visiting verifier to review practical work.

After we have received and accepted an application, we will send an approval letter confirming this. You can then send entries in at any time using the International Directory of Examinations and Assessments for guidance.

City & Guilds reserves the right to suspend an approved centre, or withdraw its approval from an approved centre or for an approved centre to conduct a particular City & Guilds scheme or particular City & Guilds schemes, for reason of debt, malpractice or for any reason that may be detrimental to the maintenance of authentic, reliable and valid qualifications or that may prejudice the name of City & Guilds.

Please note that in this section we have provided an overview of centre approval procedures. Please refer to the current issue of 'Delivering International Qualifications – Centre Guide' for full details of each aspect of these procedures.

Other information

Designing courses of study

Candidates for the various Technician Awards in Telecommunication Systems will have come from different backgrounds and will have different employment and training experiences. We recommend the following:

- carry out an assessment of the achievements so you can see what learning they already have and decide the level of entry they will need; and
- consider what learning methods and places will best suit them.

When you assess a candidate's needs, you should design teaching programmes that consider:

- what, if any, previous education qualifications or training the candidate has, especially in the various general vocational education certificates we provide; and
- what, if any, previous practical experience the candidate has which is relevant to the aims of the programme and from which they may have learned the relevant skills and knowledge.

When you choose learning methods and places, you should consider the results of your assessments and whether the following are available.

- Open or distance learning material.
- Workplace learning that can be carried out on site or between you and a local workplace. This will allow the candidates access to specialised equipment and work experience.
- Working with other registered centres to share facilities.
- Opportunities for co-operative learning between candidates for different certificates who need to gain similar skills.

As long as the candidates meet the aims of this learning programme the structures of courses of study are up to you. So, it is possible to include extra topics that meet local needs.

However, we strongly advise you to offer the following components during the first year of the diploma course, and we also strongly advise that you to test candidates on those components at the end of that year:

- 2730-02-011 Fundamentals of Electronic Communication 2
- 2730-02-012 Communication Systems and Digital Networks 2

We recommend the following components are offered during, and tested at the end of, the second year of the Diploma course:

- 2730-02-013 Fundamentals of Electronic Communication 3
- 2730-02-014 Communication Systems and Digital Networks 3

Again, we recommend that candidates should start with their chosen optional component in year one, completing it at the end of year two of the Diploma.

Candidates who have chosen Advanced Mathematics 1 should start with this component in year one, after having finished the Applied Mathematics unit in component 011. The test should take place at the end of year one, to give candidates the chance to repeat this component in the second year.

You should avoid teaching theory alone. As far as possible the practical work should be closely related to work in the classroom (integrative approach) so that candidates use their theory in a realistic work environment. We recommend that you start with practical assignments at an early stage in year one of the Diploma.

You can use formal lectures in the classroom with appropriate exercises and demonstrations. Candidates should keep records of the practical work they do so they can refer to it at a later date.

We assume that you will include key skills, such as numeracy, communication, working with people, and organisation and planning throughout a teaching programme.

Presentation format of units

Practical competences

Each unit starts with a section on practical competences which shows the practical skills candidates must have.

At times we give more detail about important words in each 'competence statement'.

For example

- 3.14 Describe various methods of communicating over a channel.
Methods: simplex (one-way communication), duplex (two-way communication), half/semi-duplex (two-way communication but only one-way at any one time), broadcast, serial, parallel

In the above statement the word 'methods' is given as a range which the candidate should be familiar with. Candidates should cover the complete range. When a range starts with the abbreviation 'eg' the candidates only need to cover some of the ranged areas or you can use suitable alternatives.

Knowledge requirements

Immediately after the section on practical competences the unit tells you what knowledge is needed for that area. The knowledge needed is closely linked to the practical competences, so it is best to teach the two together so that the candidate appreciates the topic more.

Practical assignments

You should make sure all practical assignments are supervised and instructors should make sure that the results reflect the candidate's own work. You must hold all the documents and material in a file (portfolio) for each candidate for eight weeks after the application for a certificate.

Entry levels

We consider the following programmes to be relevant preparation for this programme.

Technician Certificate in Telecommunication Systems (2730)
Background to Technology (3660)

We also consider the following Pitman Qualifications award as relevant alongside this programme.

English for Speakers of Other Languages – higher intermediate level

We also consider the following joint City & Guilds and NEBS Management award as relevant alongside this programme.

International Management Award – Principles of Management

If candidates do not have the above qualifications, they should have secondary school leaving passes in English and mathematics and science.

Progression routes and recognition

We consider the following programmes to be relevant progression routes from this programme.

Advanced Diploma Awards in Engineering (2565)
Advanced Diploma Awards in Telecommunication Systems (2730)
Advanced Diploma Awards in Electrical and Electronic Engineering (8030)

A number of universities and other higher education institutions may accept success at diploma and certificate (with appropriate experience) level for direct entry onto bachelor degree programmes. They may also accept success at the advanced diploma level for advanced entry into the second year of these programmes. The decision to accept a candidate onto a degree programme, and the level of entry is at the discretion of the individual institution.

Useful publications

We have listed relevant text books covering specific areas of this programme in each section and also can provide a list of suggested text books. We may also have knowledge about other support materials. You should make sure that you have the latest information. We will automatically send updated lists to centres we have approved to offer this programme.

We offer the following publications as additional support materials to help you plan the delivery of International Vocational Qualifications:

Guide to the assessment of practical skills in International Vocational Qualifications

Preparing projects & portfolios for International Vocational Qualifications

Quality Handbook for Visiting Verifiers & Quality Inspectors

Syllabus

IVQ in Telecommunication Systems 2730

Component and section numbers

Technician Diploma

011 Fundamentals of Electronic Communication 2

- 01 Applied mathematics
 - 02 Boolean algebra, logic gates and relaxation oscillators
 - 03 Telecommunication systems and networks
 - 04 Noise
 - 05 Logarithms and decibels
 - 06 Transmission lines
 - 07 The basic principles of filters and radio frequency (r.f.) oscillators
 - 08 Modulation
-

012 Communication Systems and Digital Networks 2

- 01 Data communication fundamentals
 - 02 The Open Systems Interconnection (OSI) reference model
 - 03 Transmission Control Protocol / Internet Protocol (TCP/IP)
 - 04 Data packets, frames and cells
 - 05 Switching and routing
-

013 Fundamentals of Electronic Communication 3

- 01 Stabilised power supplies
 - 02 Optical fibre systems
 - 03 Modulation
 - 04 Digital transmission and multiplexing
 - 05 Pulse modulation and Time Division Multiplex (TDM) systems
 - 06 Access networks and digital telephone exchanges
-

014 Communication Systems and Digital Networks 3

- 1 Structured cabling
 - 2 Local Area Networks (LANs), Metropolitan Area Networks (MANs) and Wide Area Networks (WANs)
 - 3 Transmission systems
 - 4 End systems
 - 5 Network management
 - 6 Internet Data Centre (IDC)
-

015 Telecommunication Systems Practice 2 / 3

016 Radio Systems

017 Radio Systems Practice

018 Programming Principles

019 Programming Principles Practice

020 Advanced Mathematics 1

011 Fundamentals of Electronic Communication 2

01 Applied mathematics

Introduction

The aim of this section is to enable the candidate to

- a acquire the fundamental mathematical knowledge for application to the diploma core components in the topic areas of communications and digital networks
- b provide the foundation for the possible study of additional mathematics as a diploma option (Advanced Mathematics 1).

Notes:

- 1 The subjects in this section would benefit if an integrative approach is used.
- 2 It is suggested that about 15 guided learning hours should be given to this section.

Book list

Computer Studies (5th edition); C. S. French.
Statistics (6th edition); W. M. Harper.
Foundation Discrete Mathematics for Computing; D. J. Booth, Thomson.
Foundation Mathematics (2nd edition); A. Croft & R. Davison, Addison-Wesley.

Practical competences

The demonstration of practical competences is not required for this section.

Knowledge requirements

The instructor must ensure the candidate is able to:

Number systems

- 1.1 Convert a compound denary number with fractions limited to $\frac{1}{32}$ s to its binary equivalent and vice versa.
- 1.2 Use a sign bit to denote a negative quantity.
- 1.3 Define the modulus, 1s and 2s complement of a binary number, using numerical examples to illustrate the definitions.
- 1.4 Add two compound binary numbers.
- 1.5 Subtract one binary number from another using complementary addition.
- 1.6 Multiply one binary number by another.
- 1.7 Divide one binary number by another.

- 1.8 Show, using numerical examples, that binary addition, subtraction, multiplication and division may be accomplished using the add method.
- 1.9 Define the octal and hexadecimal number systems and convert binary numbers to octal and hexadecimal forms.
- 1.10 Express octal and hexadecimal numbers in binary form.
- 1.11 Define the 8421 Binary Coded Decimal (BCD) system and derive the BCD equivalents of denary numbers.
- 1.12 Convert between denary numbers and their BCD equivalents.
- 1.13 Perform simple addition and subtraction using BCD and hexadecimal integer numbers.

Basic statistics

- 1.14 Calculate the arithmetic mean for ungrouped data.
- 1.15 Arrange ungrouped data in rank order and determine the median and modal values.
- 1.16 Calculate the arithmetic mean for grouped data.
- 1.17 Estimate the modal value of grouped data using a histogram.
- 1.18 Construct a cumulative frequency graph from a given frequency distribution.
- 1.19 Determine the median, quartiles, deciles and percentiles from cumulative frequency data.
- 1.20 Explain the circumstances most appropriate for the use of each of the three measures of location: arithmetic mean, median and mode.
- 1.21 Define the variance, and hence the standard deviation as a measure of dispersion.
- 1.22 Calculate values of standard deviation for ungrouped data and grouped data.
- 1.23 Calculate the range and semi-interquartile range as simple alternative measures of dispersion.

011 Fundamentals of Electronic Communication 2

02 Boolean algebra, logic gates and relaxation oscillators

Introduction

The aim of this section is to enable the candidate to

- a understand the basics of combinational logic
- b apply the rules of Boolean algebra to logic gates.

Notes:

- 1 It is suggested that about 16 guided learning hours should be given to this section.

Book list

Electronic Logic Circuits (3rd edition); J.R. Gibson and Butterworth.

Success in Electronics; Tom Duncan and John Murray.

Practical competences

The candidate must be able to do the following:

- 2.1 Use the laws of Boolean algebra and minimisation techniques in order to develop a practical application of a pre-determined task.

Knowledge requirements

The instructor must ensure the candidate is able to:

- 2.2 State that Boolean algebra is a mathematical treatment of logical processes.
- 2.3 Define the basic Boolean operations of NOT, AND and OR.
- 2.4 Demonstrate, using simple examples, that all the possible outcomes of a logical process may be summarised using a truth table.
- 2.5 Demonstrate, using simple switch circuits, the following laws of Boolean algebra:
 $A.B = B.A$, $A.1 = A$, $A.0 = 0$, $A.A = A$, $A.\bar{A} = 0$ and $\bar{\bar{A}} = A$
- 2.6 Demonstrate the following further laws of Boolean algebra:
 $A + B = B + A$, $A + 1 = 1$, $A + 0 = A$, $A + A = A$, $A + \bar{A} = 1$,
 $A.B.C = A.(B.C) = (A.B).C$,
 $A + B + C = (A + B) + C = A + (B + C)$, $A.(B + C) = A.B + A.C$,
 $A + B.C = (A + B).(A + C)$
- 2.7 Sketch the British Standard and US military symbols for NOT, AND, OR, NAND and NOR elements.
- 2.8 Construct truth tables for the elements in 2.7.
- 2.9 Explain how the logic elements in 2.7 may be used to implement Boolean expressions.

- 2.10 Describe a bistable as a two-state circuit that can act as a memory.
- 2.11 Explain how a bistable may be implemented with either NAND or NOR elements.
- 2.12 Construct the truth tables for the bistable elements described in 2.11.
- 2.13 Construct a truth table for a given logic function with up to three input variables.
- 2.14 Use a truth table to derive a Boolean expression for the output function in terms of the input variables.
- 2.15 Determine the logic network to realise the Boolean expressions derived in examples of 2.14.
- 2.16 Show how a Boolean expression may be represented by a Karnaugh map.
- 2.17 Derive the Boolean expression defined by a given Karnaugh map with up to three input variables.
- 2.18 Minimise a logic function of up to three variables using:
 - i Boolean algebra
 - ii Karnaugh map grouping techniques.
- 2.19 State and prove, using truth tables, DeMorgan's theorem.
- 2.20 Describe the implications of DeMorgan's theorem in the implementation of logic functions.
- 2.21 Explain the principles and applications of UnCommitted Logic Arrays (UCLAs) for the implementation of Boolean operations.
- 2.22 Derive NOT, AND and OR functions using only NAND or NOR logic elements.
- 2.23 Produce a given Boolean operation from a given set of logic elements.
- 2.24 Distinguish between relaxation and sinewave oscillators.
- 2.25 Explain and compare the meanings of
 - i astable
 - ii monostable
 - iii bistable.
- 2.26 Draw the symbols for the elements stated in 2.25 i), ii), iii).
- 2.27 Describe, using waveform diagrams, the operation of the circuits drawn in 2.25 i), ii), iii).
- 2.28 Explain applications for the circuits in 2.25 i), ii), iii).

011 Fundamentals of Electronic Communication 2

03 Telecommunications systems and networks

Introduction

The aim of this section is to enable the candidate to

- a acquire the skills and understanding which relate to simple telecommunication networks and the range of signals carried.

Notes:

- 1 It is suggested that about 15 guided learning hours should be given to this section.

Book list

Audio, Video and Data Telecommunications; David Peterson.

Practical competences

The demonstration of practical competences is not required for this section.

Knowledge requirements

The instructor must ensure the candidate is able to:

- 3.1 Explain that telecommunication systems involve:
 - i the transfer of information
 - ii the conditioning/coding of signals prior to transfer
 - iii the conditioning/decoding of signals after transfer.
- 3.2 Describe the need for direct current (d.c.) power supplies when using electronic devices.
- 3.3 Explain the terms:
 - i signal gain
 - ii signal loss
 - iii signal distortion (shape).
- 3.4 Explain that the processes of
 - i amplification provides gain
 - ii attenuation provides loss.
- 3.5 Explain the difference between voltage gain, current gain and power gain.
- 3.6 Define the term frequency and explain that
 - i signals may be present or may be produced at different frequencies
 - ii amplification can be provided at different frequencies
 - iii attenuation may exist or may be produced at different frequencies.
- 3.7 Explain that amplifiers may be implemented by the use of discrete components with Bipolar Junction Transistors (BJTs) or with Field Effect Transistors (FETs).
- 3.8 Explain that amplifiers may be implemented by the use of integrated circuit operational amplifiers (op-amps).
- 3.9 Describe the sources of conducted and radiated interference.
Sources: electromagnetic radiation, unwanted signals
- 3.10 Describe sources of distortion.
Sources: non-linearity, harmonics
- 3.11 Describe the properties of differing types of transmission links (channels).
Properties: typical attenuation in dB/km, susceptibility to interference, unwanted radiation of signals
Fixed links: wired (shielded and unshielded copper multipairs, shielded and unshielded copper twisted pairs, copper coaxial), optical fibre, waveguide, point-to-point wireless (line-of-sight), geostationary satellite
Mobile links: wireless (radio), infrared, non-geostationary satellite
- 3.12 Explain the main features of signal waveforms.
Features: amplitude, frequency, phase, wave shape, complex
- 3.13 Explain that complex waveforms can be considered as consisting of a combination of sinusoidal waveforms.
- 3.14 Describe various methods of communicating over a channel.
Methods: simplex (one-way communication), duplex (two-way communication), half/semi-duplex (two-way communication but only one-way at any one time), broadcast, serial, parallel
- 3.15 Describe the frequency ranges of speech, music and video waveforms.
- 3.16 Explain why the higher frequencies in the speech range are not essential for effective communication.
- 3.17 Explain why, for good quality, music requires a greater frequency range than speech.
- 3.18 Explain why the greater the picture definition, the greater the video bandwidth required.
- 3.19 Explain the difference between baseband and broadband signals.
- 3.20 Describe the bandwidth of common analogue signals.
Signals: commercial speech, hi-fi music, sound broadcasting (l.f./m.f. and very high frequency (v.h.f.)), monochrome (black-and-white television), colour television

- 3.21 Explain that a signal is attenuated due to losses in a cable.
- 3.22 Describe the need to amplify the signal at regular intervals along the line.
- 3.23 Describe the need for four-wire working.
- 3.24 Describe, with the aid of a diagram, the operation of a 2-4 wire conversion unit.
- 3.25 Describe how a four-wire circuit could become unstable.

011 Fundamentals of Electronic Communication 2

04 Noise

Introduction

The aim of this section is to enable the candidate to understand

- a the nature and sources of noise
- b the effect of noise on telecommunications.

Notes:

- 1 It is suggested that about 14 guided learning hours should be given to this section.

4.13 Solve problems relating to F and NF.

4.14 Define thermal (Johnson) noise.

4.15 Explain that the thermal noise producing voltage (v_n) for a resistance is given by the formula:
$$v_n = \sqrt{4kTBR} \text{ volts}$$

4.16 Solve simple problems using the equation in 4.15.

4.17 Define noise temperature (T_n).

Book list

Modern Electronic Communication (7th Edition); Gary Miller.
Electronic Communications Systems, William L. Schweber.

Practical competences

The demonstration of practical competences is not required for this section.

Knowledge requirements

The instructor must ensure the candidate is able to:

- 4.1 Define noise in the context of communication systems.
- 4.2 Describe the effects of noise in communication systems.
- 4.3 Explain the sources of noise as man-made and natural.
- 4.4 Describe the sources of internal noise.
Sources: thermal/Johnson, shot, flicker
- 4.5 Describe the sources of external noise.
Sources: natural (eg sun, moon, sky, galactic, cosmic), artificial/man-made (eg ignition systems, rotating machinery)
- 4.6 List examples of the noise which may arise from the sources defined in 4.3 and 4.4.
- 4.7 Distinguish between 'impulsive noise' and 'white noise'.
- 4.8 Define signal/noise ratio and express it in deciBels (dB).
- 4.9 Explain how the signal/noise ratio determines the accuracy with which received information can be identified.
- 4.10 Solve problems relating to signal/noise ratios.
- 4.11 Define noise Factor (F).
- 4.12 Define Noise Figure (NF).

011 Fundamentals of Electronic Communication 2

05 Logarithms and decibels

Introduction

The aim of this section is to enable the candidate to

- a apply the laws of logarithms to linear equations in order to simplify gain/attenuation calculations.

Notes:

- 1 It is suggested that about 15 guided learning hours should be given to this section.

Book list

Electronic Communications Systems; William L. Schweber.

Practical competences

The candidate must be able to do the following:

- 5.1 Apply the laws of logarithms in order to express in a convenient form the gain or attenuation of telecommunications systems.
Gain: current, voltage, power

Knowledge requirements

The instructor must ensure the candidate is able to:

Logarithms and indicial equations

- 5.2 Define a logarithm to any base.
- 5.3 Convert a simple indicial equation to a logarithmic relationship and vice versa.
- 5.4 Deduce the laws of logarithms for any base b in the following forms:
 $\log_b(xy) = \log_b x + \log_b y$; $\log_b(x/y) = \log_b x - \log_b y$; $\log_b(x^a) = a \log_b x$
- 5.5 State that $\log_b 1 = 0$ and $\log_b b = 1$.
- 5.6 State that as $x \rightarrow 0$, $\log_b x \rightarrow -\infty$
- 5.7 Apply the laws of logarithms to simplify expressions.
- 5.8 Apply the laws of logarithms to solve equations.
- 5.9 State the base e of natural logarithms is approximately 2.718.
- 5.10 Define natural (Napierian) logarithms ($\log_e x$ or $\ln x$).
- 5.11 Evaluate expressions and solve equations using natural logarithms.

- 5.12 Deduce the relationship between natural and common logarithms.
- 5.13 Change the base of numbers using the laws of powers, eg $16 = 4^2$, $27 = 3^3$
- 5.14 Change the base of numbers where the index is in algebraic form, such as $8^x = 2^{3x}$
- 5.15 Solve indicial equations where the indices are linear in one unknown.
- 5.16 Solve indicial equations where the indices are quadratic in one unknown.
- 5.17 Derive, from 'blackbox' models, the power gain or loss (attenuation) of a network or system.
- 5.18 Determine the advantages of the use of logarithmic units when
 - i dealing with large ranges of numbers
 - ii calculating the power gain or loss of networks connected in tandem.
- 5.19 Define the decibel (dB).
- 5.20 Define the dBm (dB relative to 1mW), and describe its use in system calculations.
- 5.21 Define:
 - i voltage gain and loss in dB
 - ii current gain and loss in dB.
- 5.22 Derive the condition for
 - i power gain in dB
 - ii voltage gain in dB
 - iii current gain in dB of a network or system.
- 5.23 Define signal/noise ratio in decibels.
- 5.24 Calculate, in dBs and as a power ratio, the overall gain and/or attenuation of simple systems given the gain/attenuation of the individual stages.

011 Fundamentals of Electronic Communication 2

06 Transmission lines

Introduction

The aim of this section is to enable the candidate to

- a understand the characteristics of transmission lines and cables used for telecommunication purposes.

Notes:

- 1 It is suggested that about 14 guided learning hours should be given to this section.

Book list

Modern Electronic Communication (7th Edition); Gary Miller.

Practical competences

The demonstration of practical competences is not required for this section.

Knowledge requirements

The instructor must ensure the candidate is able to:

- 6.1 Describe the effect of metallic cables on analogue and digital signals.
- 6.2 Explain the four primary coefficients of a transmission line and sketch an equivalent circuit for a section of line.
Coefficients: R, G, L and C
- 6.3 Describe why, in unloaded cables, R and C are the most significant primary coefficients and produce the effect of a low-pass filter.
- 6.4 Define the terms commonly used in relation to a transmission line.
Terms: characteristic impedance (Z_0), attenuation coefficient (a), phase-change coefficient (b)
- 6.5 Sketch typical attenuation/frequency and delay/frequency response curves for unloaded and loaded cable, and coaxial cable.
- 6.6 Describe the shape of the response curves in 6.5 in terms of the primary coefficients of the cables used.
- 6.7 Define the terms used in relation to the distortion effects of a rectangular pulse.
Terms: rise-time, sag
- 6.8 Explain the relationship between the 3dB bandwidth of a RC low-pass filter to which a rectangular pulse is applied and the rise-time of the output pulse.
- 6.9 Explain how the attenuation/frequency and delay/frequency characteristics of a cable affect analogue bandwidth and digital bitrate.
- 6.10 Describe the propagation of an electromagnetic wave along a twin transmission line.
- 6.11 Explain why negligible radiation occurs from twin or concentric lines.
- 6.12 Explain that steady current conditions do not apply in the case of lines energised at radio frequencies.
- 6.13 Sketch an equivalent loss-free line in terms of its distributed L and C parameters.
- 6.14 Explain that maximum power can be drawn from the line if its terminating load has a particular value.
- 6.15 Explain that, unless maximum power is drawn from the line, reflection will occur.
- 6.16 Define the characteristic impedance Z_0 of a line as equal to the value of the terminating load that causes no reflection and hence absorbs maximum power.
- 6.17 State the value of Z_0 in terms of the distributed L and C parameters of a loss-free line.
- 6.18 Explain that Z_0 is the ratio of root mean square (r.m.s.) voltage to r.m.s. current for a wave propagated on a line which is terminated in its characteristic impedance.
- 6.19 Describe in simple terms, by considering voltage conditions, how a short-circuited termination causes total reflection.
- 6.20 Describe in simple terms how an open-circuited termination causes total reflection.
- 6.21 Show diagrammatically how reflection produces a standing wave.
- 6.22 Describe the effects of reflected waves in pulse systems.
- 6.23 Distinguish between travelling and standing waves.
- 6.24 Describe how the conductor and spacing dimensions of open-wire lines and coaxial cables affect the value of characteristic impedance.
- 6.25 State typical values of Z_0 for open-wire and coaxial cables.

011 Fundamentals of Electronic Communication 2

07 The basic principles of filters and radio frequency (r.f.) oscillators

Introduction

The aim of this section is to enable the candidate to

- a determine the characteristics of inductance and capacitance, and their application to basic filters and oscillator circuits.

Notes:

- 1 It is suggested that about 10 guided learning hours should be given to this section.

Book list

Modern Electronic Communication (7th Edition); Gary Miller.

Practical competences

The demonstration of practical competences is not required for this section.

Knowledge requirements

The instructor must ensure the candidate is able to:

- 7.1 Sketch frequency response characteristics for filter networks and indicate the 3 dB frequency.
Filters: low-pass, high-pass, band-pass, band-stop
- 7.2 Sketch waveforms to show the effects of passing a complex wave through low-pass and high-pass filter circuits.
- 7.3 Identify from the frequency plots types of filter and sketch their standard block symbols.
Filters: low-pass, high-pass, band-pass, band-stop
- 7.4 Determine the ultimate rate of signal voltage attenuation for a single-pole RC filter circuit (6dB/octave / 20dB/decade).
- 7.5 Describe in simple terms that the instantaneous currents in a parallel LC circuit flow in opposite directions.
- 7.6 Explain that at one particular frequency the currents in a parallel LC circuit become equal and opposite and hence that a parallel LC circuit has a high impedance at resonance.
- 7.7 State expressions, and calculate typical values, for the resonant frequency and dynamic impedance of a parallel LC circuit.

- 7.8 Explain that an amplifier is an active device (black box treatment) by which a small input voltage variation can be used to control current from a battery.
- 7.9 Explain that the voltage gain depends upon the value of the load connected in the output circuit of the amplifier.
- 7.10 Explain that an amplifier using a parallel LC circuit as a load will have maximum voltage gain at the resonant frequency.
- 7.11 Describe how a fraction of the voltage across the load can be used to provide the amplifier input signal.
- 7.12 Describe an r.f. oscillator as a self-driven amplifier with a parallel LC circuit as the load.
- 7.13 Describe the tuning of r.f. oscillators by the adjustment of L and C.

011 Fundamentals of Electronic Communication 2

08 Modulation

Introduction

The aim of this section is to enable the candidate to

- a explain the principles of communicating information by varying the characteristics of a waveform
- b investigate the characteristics of various waveforms and the manner in which they can be varied in order to convey information
- c describe the characteristics of modulated signals.

Notes:

- 1 The subjects in this section would benefit if an integrative approach is used.
- 2 It is suggested that about 16 guided learning hours should be given to this section.

Book list

Modern Electronic Communication (7th Edition); Gary Miller.

Practical competences

The demonstration of practical competences is not required for this section.

Knowledge requirements

The instructor must ensure the candidate is able to:

Basic principles

- 8.1 Explain the need for modulation.
- 8.2 Describe modulation as the process of superimposing information on a carrier wave.
- 8.3 Explain that modulation is the process whereby some property of a carrier wave is varied by a baseband wave.
- 8.4 Identify, from given waveform diagrams, the modulated wave for:
 - i Amplitude Modulation (AM)
 - ii Frequency Modulation (FM)

Amplitude modulation

- 8.5 Sketch an AM waveform in which the modulating signal is a sine wave.
- 8.6 Show diagrammatically how audio frequency information may be superimposed upon a radio frequency carrier wave by varying its amplitude.
- 8.7 Sketch typical waveforms of a radio frequency (r.f.) carrier wave (f_c) amplitude-modulated by a sinusoidal tone (f_m); hence describe modulation depth.

- 8.8 Describe how am of an r.f. carrier wave by a sinusoidal tone produces a complex wave having three frequency components:

- i f_c
- ii $f_c - f_m$
- iii $f_c + f_m$

- 8.9 Show graphically that the modulated wave can be constructed from waveforms of carrier (f_c), and side frequencies ($f_c +$ and $- f_m$).

- 8.10 Define modulation depth as applied to an AM waveform.

- 8.11 Explain why modulation exceeding 100% results in distortion which appears in the demodulated output.

- 8.12 Describe, with the aid of a frequency spectrum diagram, the components of a double-sideband AM signal.

- 8.13 Describe, with the aid of a frequency spectrum diagram, the components of a single-sideband AM signal.

- 8.14 Describe the advantages of single-sideband systems with specific reference to power, bandwidth and noise.

- 8.15 Describe the bandwidth requirements of a modulated carrier.

- 8.16 Show, by means of waveforms, demodulation as the process of recovering the audio frequency (a.f.) information from the envelope of a modulated wave.

- 8.17 Explain why over-modulation results in distortion which appears at the demodulated output.

Frequency Modulation (FM) and Phase Modulation (PM)

- 8.18 Explain that FM is the variation of the frequency of a carrier in accordance with the instantaneous value of a baseband signal.

- 8.19 Describe the terms used in FM.

Terms: frequency deviation, maximum deviation, deviation ratio

- 8.20 Explain that PM is the variation of the phase of a carrier in accordance with the instantaneous value of a baseband signal.

- 8.21 Show diagrammatically how a.f. information can be superimposed upon a radio frequency carrier wave by causing its frequency to deviate.

- 8.22 Explain that the frequency deviation of the carrier wave depends upon the amplitude of the modulating signal but that the amplitude of the carrier wave is unchanged.

- 8.23 Explain why the bandwidth required for an FM service is rather more than twice the maximum deviation.
- 8.24 Explain why FM radio services operate at very high frequency (v.h.f.) and above.
- 8.25 Sketch and describe the frequency/amplitude characteristic of a discriminator suitable for demodulating an FM signal.

Assessment

Test specification for written paper Fundamentals of Electronic Communication 2 (2730-02-011)

This is a written examination paper lasting three hours with ten questions. Candidates must answer **all** questions.

The examination paper will cover the knowledge specifications:

Topic	Approximate % examination weighting
01 Applied mathematics	14
02 Boolean algebra, logic gates and relaxation oscillators	16
03 Telecommunication systems and networks	14
04 Noise	8
05 Logarithms and decibels	14
06 Transmission lines	12
07 The basic principles of filters and radio frequency (r.f.) oscillators	8
08 Modulation	14

012 Communication Systems and Digital Networks 2

01 Data communication fundamentals

Introduction

The aim of this section is to enable the candidate to understand

- a the general concept of data networks
- b fundamental data networking terminology.

Notes:

- 1 It is suggested that about 10 guided learning hours should be given to this section.

Book list

Business Data Communications (4th edition); Jerry Fitzgerald.
Business Data Communications (4th edition); Stallings, Van Styke.
Business Data Communications and Networking (7th edition); Jerry FitzGerald, Alan Dennis.
Data Communications for Engineers; Michael Duck, Richard Read.
Data and Computer Communications (6th edition); William Stallings.

Practical competences

The candidate must be able to do the following:

- 1.1 Draw a block diagram illustrating and identifying the components necessary to establish two-way communication between two computers over a public telephone network system.
- 1.2 Locate and activate terminal emulation software on a computer and record the parameter settings in the configuration section of the software.
Parameter: bits per second (bps), bits, parity, stop bit, flow control

Knowledge requirements

The instructor must ensure the candidate is able to:

- 1.3 Identify the components of a simple communication system.
Components: source, transmitter, transmission system, receiver, destination
- 1.4 Describe the different media used in data communication.
Media: copper cable, fibre optical cable, radio waves
- 1.5 Explain the difference between digital and analogue signals.
- 1.6 Explain the meaning of bits and bytes in the context of data communication.
Bits: binary digits
Bytes: binary word

- 1.7 Describe the data formats of digital transmission.
Data formats: serial, parallel
- 1.8 Describe the two forms of serial transmission.
Forms: synchronous, asynchronous
- 1.9 Explain what is meant by
 - i circuit switching
 - ii message switching
 - iii packet switching
 - iv fast packet switching.
- 1.10 Compare and contrast the relative advantages and disadvantages of each of the switching methods listed in 1.9.
- 1.11 Describe the difference between connectionless (eg datagram) and connection-oriented (eg virtual circuit) packet switched networks.
- 1.12 Compare and contrast the relative advantages of the packet switching methods listed in 1.11.
- 1.13 Explain the meaning of the term 'protocol' in the context of data communication.
- 1.14 Describe what is meant by each of the following:
 - i source coding
 - ii channel coding
 - iii line coding.
- 1.15 Give examples of each method of coding listed in 1.14
- 1.16 Describe in relation to data communications what is meant by
 - i data
 - ii information
 - iii redundancy
- 1.17 Compare and contrast the two basic methods of error correction.
Methods: Automatic Repeat Request (ARQ), Forward Error Control (FEC).

012 Communication Systems and Digital Networks 2

02 The Open Systems Interconnection (OSI) reference model

Introduction

The aim of this section is to enable the candidate to understand

- a the purpose of the OSI
- b the main functions of each layer of the OSI
- c how the OSI relates to data networks
- d how network devices and protocols map onto the OSI.

Notes:

- 1 It is suggested that about 25 guided learning hours should be given to this section.

Book list

OSI Explained: End-To-End Computer Communication Standards;
John Henshall and Sandy Shaw.
OSI Reference Model for Telecommunications; *Debbra Wetteroth.*

Practical competences

The candidate must be able to do the following:

- 2.1 Set up two computers for communication over a Local Area Network (LAN) in order to facilitate the interaction of two software applications between the two machines.
- 2.2 Map the communication link and application dialogue onto a diagram and explain the processing that takes place at each layer of the OSI.

Knowledge requirements

The instructor must ensure the candidate is able to:

- 2.3 Provide the International Standards Organisations (ISO) reasons for the development of the OSI seven layer reference model.
- 2.4 Explain that OSI, as a standard is a logical framework defining the various protocol levels that are possible in a network implementation, without actually specifying the implementation strategy.
- 2.5 List all seven layers of the OSI and describe the function of each layer as well as giving an example of layer implementation.
Function: layer one, physical-level issues, voltages, connectors, medium
Example: International Telecommunications Union (ITU)-T X.21
- 2.6 Explain the peer-to-peer communication concept of the OSI layers between adjacent systems.

- 2.7 Explain the terms 'encapsulation', 'segmentation' and 'fragmentation' with reference to data and the layers of the OSI.
- 2.8 Explain that all layers do not have to be represented in every LAN implementation.
Implementation: NetBEUI
- 2.9 Explain that the structure of the OSI is such that the higher-numbered layers build upon and utilise the services of the lower layers.
- 2.10 Describe the advantages and disadvantages of the OSI networking model concept.

012 Communication Systems and Digital Networks 2

03 Transmission Control Protocol / Internet Protocol (TCP/IP)

Introduction

The aim of this section is to enable the candidate to understand the

- a general concepts of the TCP/IP protocol suite
- b application and implementation of TCP/IP.

Notes:

- 1 It is suggested that about 30 guided learning hours should be given to this section.

Book list

Computer Networks & Internets with Internet Applications (with CD-ROM); Douglas E. Comer and Ralph E. Droms.
Internetworking with TCP/IP, Vol 1: Principles, Protocols and Architecture; Douglas Comer.

Practical competences

The candidate must be able to do the following:

- 3.1 Identify TCP/IP numbers and classes.
Numbers: ports, IP addresses
Classes: A, B, C, D, E
- 3.2 Produce a report showing the development of the TCP/IP suite of protocols.
- 3.3 Produce an IP addressing scheme, which includes the use of subnets.
- 3.4 Use the ping command.

Knowledge requirements

The instructor must ensure that the candidate is able to:

- 3.5 Conduct a literature or Web-based research on the TCP/IP suite of protocols.
- 3.6 Give reasons for use of protocols in data communication, using everyday analogies where appropriate.
Analogies: social interactions, greetings, telephone conversations
- 3.7 Produce a concise outline of the main features of the TCP/IP protocol, referencing the Department Of Defence (DOD) protocol model and compare with it the International Standards Organisation (ISO)/Open Systems Interconnect (OSI) model.

- 3.8 Outline in detail, the function and operation of the TCP protocol.
Function: data recovery, flow control, guaranteed delivery
Operation: three-way handshake, port allocation, data segmentation
- 3.9 Sketch the IP version 4 datagram format and briefly explain the function of the different fields.
- 3.10 Outline the function and operation of the IP protocol.
- 3.11 Identify the layer of the OSI model at which the IP protocol operates.
- 3.12 List the individual layers of the TCP/IP model and explain their functions.
Layers: application layer, transport layer, Internet layer, network access layer
- 3.13 List the 'well-known' TCP port numbers and state the function of each port.
Ports: 21-file transfer protocol (ftp), 23-telnet, 25-simple mail transfer protocol (smtp), 80-hyper text transfer protocol (http)
- 3.14 Identify and explain the purpose and function of a protocol for each layer of the TCP/IP protocol suite.
- 3.15 List the 'well-known' User Datagram Protocol (UDP) port numbers and state the function of each port.
Ports: 53-Domain Name Service (DNS), 69-Trivial File Transfer Protocol (TFTP)
- 3.16 Explain base 2 and base 10 numbering systems and convert from one to the other using binary and dotted decimal notation of IP addresses.
- 3.17 Explain the classful Internet addressing scheme, identifying the classes and their default subnet masks, network and host ranges.
- 3.18 Explain why there is a need for subnetting and how subnetting is implemented.
- 3.19 Identify broadcast addresses within a subnetted network-addressing scheme.
- 3.20 Identify the network and host portions of a given complete IP address and subnet mask.
- 3.21 Calculate subnet addresses and list the host ranges for each subnet within a given subnetted. IP addressing scheme.
- 3.22 Give reasons for the allocation of reserved IP addresses.
Reserved addresses: loopback, unassigned, private
- 3.23 Explain who is responsible for allocating IP addresses for use on the Internet.

- 3.24 Explain the purpose and use of Dynamic Host Configuration Protocol (DHCP) and DNS.
- 3.25 Explain the role of routers within interconnected IP networks.

012 Communication Systems and Digital Networks 2

04 Data packets, frames and cells

Introduction

The aim of this section is to enable the candidate to understand

- the basic principles of using packets, frame and cells for data transmission
- the concept of data encapsulation
- the data structure of packets, frames and cells
- the common standards and protocols used for data transfer.

Notes:

- It is suggested that about 18 guided learning hours should be given to this section.

Book list

Computer Networks (3rd edition); Andrew S. Tanenbaum.

Data and Computer Communications (6th edition); William Stallings.

Introduction to Data Communications and Networking; Behrouz Forouzan, Catherine Ann Coombs and Sophia Chung Fegan.
Networking Complete; Sybex Inc.

Practical competences

The demonstration of practical competences is not required for this section.

Knowledge requirements

The instructor must ensure the candidate is able to:

Concepts of data transmission and commonly used terms

- Understand what data communication is and what the key elements are in data communication.
Elements: source, transmitter, transmission system, receiver, destination
- Understand the difference between digital and analogue signals and between packet switching and circuit switching.
- Explain concepts and terminology of data transmission.
Concepts and terminology: protocols, frames, packets, guided media, point-to-point, bandwidth, data
- Discuss media channel capacity including Nyquist formulation as well as the Shannon capacity formula.
- Explain transmission impairments and how they are tackled.
Impairments: attenuation, delay distortion, noise

- Discuss the role of standards and standards bodies in data communications.
Standards: Institute of Electrical and Electronics Engineers (IEEE) 802.2, 802.3
Bodies: IEEE, Asynchronous Transfer Mode (ATM) forum
- Explain data encoding and list examples of encoding schemes.
Examples: Pulse Code Modulation (PCM), Frequency-Shift Keying (FSK), Manchester
- Explain the difference between synchronous and asynchronous transmissions and between half-duplex and full duplex transmissions.
- Explain the difference between Data Terminal Equipment (DTE) and Data Circuit-terminating Equipment (DCE) and list examples.
Examples: DTE Computer, DCE Modem
- State the different standards for data communications interface.
Standards: V.24/EIA-232-F, X.21

Data Link Control

- Explain the role of the data link layer in the OSI and give examples of data link layer protocols.
Examples: HDLC, Logical Link Control (LLC)
- Understand how flow control is implemented at the data link layer as well as listing and explaining the different flow control methods.
Methods: stop-and-wait, sliding-window
- Explain error detection and control in data transmission and give examples of error-detection schemes.
Examples: parity check, Cyclic Redundancy Check (CRC), Hamming
- Describe in detail the HDLC protocol explaining basic characteristics, frame structure and operation.
- Describe the basic construction, operation and facilities offered by frame relay.
Construction: format and size
- Understand the main factors which make the frame relay protocol capable of higher bit rates than the standard HDLC protocol.
Factors: reduced error checking, existence of error checking, recovery in higher-level protocols

- 4.20 Understand the basic construction, operation and facilities provided by the X.25 packet switching protocol.
Construction: format, size
Operation: Link Access Procedure Balanced (LAPB), incoming and both-way, set-up and clear-down, Switched Virtual Circuit (SVC) and Permanent Virtual Circuit (PVC)
Facilities: routing by Network User Address (NUA), error checking, cyclic count, Packet Assembler/Disassembler (PAD), fault logging
- 4.21 Understand the basic construction, operation and facilities offered by the ATM protocol.
Construction: format, size, Virtual Path Identifier (VPI), Virtual Channel Identifier (VCI)
Facilities: Quality of Service (QoS)
- 4.22 Describe the IEEE 802.3 frame format and explain the function of each field.
Fields: preamble, Start Frame Delimiter (SFD), Destination Address (DA), Source Address (SA), length type, LLC data, pad, Frame Check Sequence (FCS)

012 Communication Systems and Digital Networks 2

05 Switching and routing

Introduction

The aim of this section is to enable the candidate to understand the

- a general concepts of switching and routing within a computer network
- b technologies used for switching and routing
- c types and purpose of protocols used within switching and routing
- d application and implementation of switching and routing in a network.

Notes:

- 1 It is suggested that about 28 guided learning hours should be given to this section.

Book list

Designing Addressing Architectures for Routing and Switching (McMillan Network Architecture and Development); Howard C. Berkowitz.
IP Switching and Routing Essentials: Principles and Protocols for Delivering Data on the Internet; Stephen Thomas.
The Switch Book: The Complete Guide to LAN Switching Technology; Rich Seifert.

Practical competences

The candidate must be able to do the following:

- 5.1 Design a network using switching and routing technologies.
- 5.2 Create configuration files for routers in a small network.
- 5.3 Conduct a literature and Web search for vendor information on routers and switches.

Knowledge requirements

The instructor must ensure the candidate is able to:

- 5.4 Describe a Local Area Network (LAN) switch and list the different switching methods employed.
Methods: cut through, store-and-forward, fragment free
- 5.5 Explain the function and operation of a layer 2 switch in a network.
Function: creates collision domains, full duplex data transfer capability, Virtual Local Area Network (VLAN) creation

- 5.6 Describe the fundamentals of the Spanning Tree Algorithm (STA) and its application in switched networks.
Application: Spanning Tree Protocol (STP)
- 5.7 Explain the concept of VLANs.
- 5.8 Comprehend that VLANs require routers to interconnect them.
- 5.9 Explain trunking and give examples of trunking protocols.
Trunking: multichannel inter-switch connections
Protocols: Institute of Electronic and Electrical Engineers (IEEE) 802.1q
- 5.10 Describe the purpose and basic function of a router in a network.
- 5.11 Explain the difference between routing and routed protocols and provide examples of each.
- 5.12 Describe connectors and interfaces used for connecting routers to a network.
Connectors: EIA/TIA-232, EIA/TIA-449, V.35, X.21, EIA-530
Interfaces: serial, Ethernet, token ring
- 5.13 Compare the features offered by competing manufacturers of networking equipment.
Features: packet forwarding rate in packets per second (pps), variety of interfaces, mean-time-between-failures (mtbf)
- 5.14 Explain and/or demonstrate the use of character based American Symbolic Code for Information Interchange (ASCII) terminal or terminal emulation software for the configuration of a router.
Software: Hyperterminal, Teraterm Pro
- 5.15 Create a configuration file for a given router. Include routing protocols, device name, interface configuration to permit router operation (simulation is acceptable).
Configuration: interface Internet Protocol (IP) addresses, routing protocols, encapsulation, clock rate, interface status
- 5.16 Explain the difference between a non-routable protocol and a routable protocol.
Difference: presence and absence of International Standards Organisation (ISO)/Open Systems Interconnect (OSI) layer 3 capabilities of the protocol suite
- 5.17 List non-routable protocols and explain their operation, advantages, disadvantages and the layer of the ISO/OSI model at which they operate.
- 5.18 List routable protocols and describe their main features.
Routable protocols: IP, Internet Packet eXchange (IPX)
- 5.19 Explain subnetting in the context of logical segmentation of networks and localisation of network traffic.

- 5.20 List examples of routing protocols and describe their functionality.
Examples: Routing Information Protocol (RIP), Intermediate System to Intermediate System (IS-IS)
- 5.21 Explain static routes and describe their advantages, disadvantages and when they should be utilised.
- 5.22 Explain dynamic routing and describe its advantages, disadvantages and how it differs from static routing.
- 5.23 Identify a network topology where dynamic routing is most suited.
- 5.24 Describe routing metrics in the context of routing protocols.
Metrics: best path, shortest path, hop count, bandwidth, delay
- 5.25 Describe the methods deployed by distance vector routing and provide examples of distance vector routing protocols.
Methods: hop count
Examples: RIP, Interior Gateway Protocols (IGP)
- 5.26 Explain the operation of RIP.
Operation: based on a distance vector algorithm
- 5.27 State the methods deployed by link-state routing protocols and provide examples of protocols which use these methods.
Methods: bandwidth, delay, traffic loading
Examples: Open Shortest Path First (OSPF)
- 5.28 Explain the purpose and function of network traffic filtering.
Filtering: access control
- 5.29 List parameters that can determine the filtering of network traffic.
Parameters: Transmission Control Protocol (TCP)/ User Datagram Protocol (UDP), port number, application, source/destination addresses, IPX, Service Advertisement Protocol (SAP) number
- 5.30 Recommend a solution in response to a Request For Proposal (RFP).

Assessment

Test specification for written paper Communication Systems and Digital Networks 2 (2730-02-012)

This is a written examination paper lasting three hours with ten questions. Candidates must answer **all** questions.

The examination paper will cover the knowledge specifications:

Topic	Approximate % examination weighting
01 Data communication fundamentals	10
02 The Open Systems Interconnection (OSI) reference model	10
03 Transmission Control Protocol / Internet Protocol (TCP/IP)	25
04 Data packets, frames and cells	25
05 Switching and routing	30

013 Fundamentals of Electronic Communication 3

01 Stabilised power supplies

Introduction

The aim of this section is to enable the candidate to

- a acquire the fundamental principles of operation of stabilised power supplies likely to be encountered in a communications environment.

Notes:

- 1 The subjects in this section would benefit if an integrative approach is used.
- 2 It is suggested that about 12 guided learning hours should be given to this section.

Book list

Power Supplies, Switching Regulators, Inverters, and Converters;
Irving M. Gottlieb.

Practical competences

The demonstration of practical competences is not required for this section.

Knowledge requirements

The instructor must ensure the candidate is able to:

The operation and use of stabilised direct current (d.c.) power supplies

- 1.1 Define the term 'regulation' as applied to a d.c. power supply.
- 1.2 Define the output resistance of a d.c. power supply.
- 1.3 Describe, with the aid of a block diagram, how a stabilised d.c. output voltage may be obtained using a voltage reference and a comparator.
- 1.4 Draw the circuit diagram and explain how a power transistor, connected as an emitter follower, may be combined with a Zener diode to form a simple series regulator.
- 1.5 Describe, with the aid of a block diagram, a complete series stabiliser which uses a d.c. amplifier, a comparator, a voltage reference and a pre-regulator
- 1.6 Describe the need for, and methods of, providing over-voltage and current limiting for a d.c. power supply.
- 1.7 Describe methods of making the output voltage of a stabilised power supply continuously variable down to zero volts.

- 1.8 Describe the types of disturbances likely to occur on power lines.
Disturbances: over-voltage, under-voltage, outage (blackout), voltage spikes, chopped voltage waveform, harmonics, electromagnetic interference
- 1.9 Explain the sources of power line disturbance.
Sources: decrease/increase in load condition, power factor correction, inductive loading, thyristors
- 1.10 Describe how an alternating current supply may be achieved by means of a d.c. battery supply.
- 1.11 Describe how an alternating current supply may be achieved by means of rotating machines.
- 1.12 Explain the function of Uninterruptible Power Supplies (UPS).
- 1.13 Explain the functions of the essential stages of UPS.
Stages: rectifier, battery bank, inverter, filter

013 Fundamentals of Electronic Communication 3

02 Optical fibre systems

Introduction

The aim of this section is to enable the candidate to

- explain the principles of communicating by light over optical fibres
- describe the characteristics of the various forms of optical fibre
- describe the characteristics of the range of light sources and receivers used for fibre optic communication systems.

Notes:

- The subjects in this section would benefit if an integrative approach is used.
- It is suggested that about 15 guided learning hours should be given to this section.

Book list

Electronic Communications Systems, William L. Schweber.
Fiber-optic Communications Technology; Djafar K. Mynbaev and Lowell L. Scheiner.
Introduction to Fiber Optics; John Crisp and Butterworth-Heinemann.

Practical competences

The demonstration of practical competences is not required for this section.

Knowledge requirements

The instructor must ensure the candidate is able to:

- Describe the structure and materials used for optical fibres.
- Explain the basic operation of fibre optic communications links.
- Explain the advantages and disadvantages of optical fibre compared to copper transmission lines.
- Identify the component parts of an optical fibre as used in communication systems.
- Explain the terms associated with optical fibres.
Terms: reflection, refraction, refractive index, core, cladding, acceptance angle, critical angle, total internal reflection
- State Snell's law and use it to calculate the angles of incidence at the core/cladding interface which will give total internal reflection, given the refractive indices of the two materials.
Snell's law: $n_1 \sin \theta_1 = n_2 \sin \theta_2$
- Adapt Snell's law to find the 'critical angle' of incidence (ie where $\theta_2 = 90^\circ$).
Critical angle: $(\theta_c) = \sin^{-1} (n_2/n_1)$
- Calculate the critical angle of incidence given the refractive indices of the materials involved.
- Explain what is meant by the Numerical Aperture (NA) of an optical fibre.
- Explain the reasons for signal power losses in optical fibres.
Losses: absorption, scattering, microbend
- Explain what is meant by dispersion in optical fibre communication systems.
- Distinguish between types of optical fibre.
Types: single-mode, multimode, graded-index, stepped-index
- Describe the structure of optical fibres giving typical dimensions.
- Describe how optical fibres may be joined and terminated.
- Justify the most commonly used wavelengths for optical fibre systems.
Wavelengths: 850 nm, 1300 nm, and 1550 nm
- State that the most commonly used transmitting devices are the Light Emitting Diodes (LED) and the Semiconductor Laser Diodes (SLD).
- Distinguish between the basic properties of the LED and the SLD.
- State safe working practices when working with optical fibres and semiconductor laser diodes.

013 Fundamentals of Electronic Communication 3

03 Modulation

Introduction

The aim of this section is to enable the candidate to

- a explain the applications of modulation
- b investigate the characteristics of various waveforms and the manner in which they can be varied in order to convey information in a digital format
- c describe the characteristics of the resultant modulated signals.

Notes:

- 1 The subjects in this section would benefit if an integrative approach is used.
- 2 It is suggested that about 16 guided learning hours should be given to this section.

Book list

Electronic Communication Systems; William Schweber.
Electronic Communication Techniques; Paul Young,
Maxwell MacMillan.
Modern Electronic Communication (7th edition); Gary Miller.

Practical competences

The candidate must be able to do the following:

- 3.1 Apply knowledge of modulation schemes to the data communication process involving serial transmission over analogue networks.

Knowledge requirements

The instructor must ensure the candidate is able to:

- 3.2 Explain why unidirectional pulse data cannot be transmitted directly over an analogue communication network.
- 3.3 Explain that different amplitudes can represent digital data in an Amplitude Modulation (AM) system.
- 3.4 Explain that digital data can be represented by different frequencies in a Frequency Modulation (FM) system.
- 3.5 Explain that digital data can be represented by different phases in a Phase Modulation (PM) system.
- 3.6 Explain that digital data can be represented by combinations of differing amplitudes and differing phases in a Quadrature-Amplitude Modulation (QAM) system.
- 3.7 Sketch typical waveforms for the systems in 3.3 to 3.6

- 3.8 Describe, with the aid of a diagram, how groups of binary digits are employed in data communication (eg coded hexadecimal).
- 3.9 Describe the function of the parity digit.
- 3.10 Explain that Frequency-Shift Keying (FSK), Phase-Shift Keying (PSK) and QAM are forms of modulation applicable to the transmission of digital data.
- 3.11 Explain the advantages of transmitting only the first pair of side frequencies.
- 3.12 Describe the main functions of a modem.
- 3.13 Distinguish between synchronous and asynchronous working and state their relative advantages.
- 3.14 Discuss the causes and nature of errors in the received digital signal in terms of noise and choice of bit rate.
- 3.15 Explain the advantages of PSK and FSK for data transmission.
- 3.16 Describe, with the aid of a block diagram, the use of the Public Switched Telephone Network (PSTN) for the transmission of digital data.
- 3.17 Describe the characteristics of typical modems.
Transmit path characteristics: clock, scrambler, encoder, modulator, filter, amplifier
Receive path characteristics: filter, amplifier, equaliser, demodulator, decoder, descrambler, clock recovery and clock
- 5.18 Describe the type of modulation used with practical modems.
Modulation: Differential Phase Shift Keying (DPSK), Quadrature Phase Shift Keying (QPSK), QAM
- 5.19 Explain the requirement for asymmetrical working for duplex modems.
- 5.20 State the function of trellis coding in modems.
- 5.21 Describe the function of cable modems and how they differ from modems designed for use over the PSTN.
- 5.22 Describe the principles and state the advantages of a dedicated data network in terms of noise reduction, faster bit rate and the elimination of the need for modems.

013 Fundamentals of Electronic Communication 3

04 Digital transmission and multiplexing

Introduction

The aim of this section is to enable the candidate to

- a determine the relevant advantages and disadvantages of digital transmission systems
- b understand the relevant characteristics of digital signals
- c appreciate that digital signals may be multiplexed together in order to share a common channel.

Notes:

- 1 It is suggested that about 16 guided learning hours should be given to this section.

Book list

Electronic Communication Systems; William Schweber.
Electronic Communication Techniques; Paul Young and Maxwell MacMillan.
Modern Electronic Communication (7th edition); Gary Miller.

Practical competences

The candidate must be able to do the following:

- 4.1 Evaluate the methods used for the transmission of digital signals.

Knowledge requirements

The instructor must ensure the candidate is able to:

Advantages of digital systems

- 4.2 Show by means of sketched waveforms how noise appears on
 - i analogue signals
 - ii rectangular pulses.
- 4.3 Explain why noise is cumulative throughout the length of an analogue communication system.
- 4.4 Describe how the effect of noise is reduced and made non-cumulative by a digital system using pulse regeneration.
- 4.5 Define the term 'bit rate'.
- 4.6 Explain the relationship between bit rate, system bandwidth and signal/noise ratio (Hartley-Shannon Law).
- 4.7 Describe how pulse regeneration enables a high bit rate to be used on a network which has a low signal/noise ratio but a wide bandwidth.

- 4.8 Explain the advantages of digital Time Division Multiplexing (TDM) systems in terms of noise reduction and cable plant utilisation cost.
- 4.9 Define the term multiplexing and name the different types used in broadband communications.
Types: space division, frequency division, time division, code division
- 4.10 Explain the need for multiplexing.
- 4.11 Explain the relationship between multiplexing and modulation.
- 4.12 Explain why de-multiplexing is more difficult than multiplexing.
- 4.13 Explain that in space division multiplexing a separate circuit is assigned to each channel and that the channels are spaced apart.
- 4.14 Describe how a common channel may be shared by means of Frequency Division Multiplexing (FDM).
- 4.15 Explain the function of guard bands in FDM.
- 4.16 Describe and illustrate by a simple diagram, the basic principle of a TDM transmission system including clock pulse trains.
- 4.17 Define the terms commonly used with TDM.
Terms: channel, time slot, guard time, sampling rate
- 4.18 Describe the relationship between sampling rate, channel time slot and the possible number of channels.
- 4.19 Sketch a simple diagram to show how signals are interleaved on the common highway.
- 4.20 Explain what is meant by 'statistical time division' multiplexing.
- 4.21 Describe how a common channel may be shared by means of 'code division' multiplexing.
- 4.22 Explain what is meant by 'multiple access' techniques in relation to frequency, time, and code division multiplexing.

013 Fundamentals of Electronic Communication 3

05 Pulse modulation and Time Division Multiplex (TDM) systems

Introduction

The aim of this section is to enable the candidate to

- a evaluate the techniques used in Pulse Amplitude Modulation (PAM) and Pulse Code Modulation (PCM) systems
- b understand the practical applications of PCM and TDM systems.

Notes:

- 1 It is suggested that about 25 guided learning hours should be given to this section.

Book list

Introduction to Digital Communications Switching (2nd edition); John Ronayne.

Modern Electronic Communication (7th edition); Gary Miller.

Practical competences

The candidate must be able to do the following:

- 5.1 Evaluate the techniques used for multiplexing voice frequency channels over the Public Switched Telephone Network (PSTN).

Knowledge requirements

The instructor must ensure the candidate is able to:

Basic principles of PAM

- 5.2 Describe, with the aid of waveform diagrams, the principles of the following types of pulse modulation.
 - i PAM
 - ii Pulse Width Modulation (PWM)
 - iii Pulse Position Modulation (PPM)
 - iv PCM
 - v Delta Modulation (DM).
- 5.3 Outline the techniques used for producing the types of modulation in 5.2 and state an application for each.
- 5.4 Explain that in a PAM system, the channel information is contained within the amplitude of the pulses and is independent of pulse width.
- 5.5 Describe, by means of a simple circuit diagram and sketched waveforms, the production of PAM.
- 5.6 Describe why the sampling rate must be at least twice the highest frequency in the baseband signal.
- 5.7 Sketch and describe the frequency spectrum of an amplitude-modulated pulse train.

- 5.8 Describe the bandwidth requirements of PAM transmission.
- 5.9 Describe the recovery of the baseband signal by means of an appropriate low-pass filter.
- 5.10 Explain the disadvantages of a PAM/TDM transmission system in terms of cumulative noise and inter-channel crosstalk.
- 5.11 Explain that a sine wave may be reconstructed from samples of its amplitude taken at more than two equally spaced intervals in its cycle.
- 5.12 Explain the minimum sampling rate needed to allow good reconstruction of an analogue signal.
- 5.13 Sketch the waveform of a pulse amplitude modulated signal.
- 5.14 Explain that the pulse train resulting from pulse-amplitude modulating an analogue signal contains the frequency of the unmodulated analogue signal together with a range of harmonics.
- 5.15 Explain that a PAM radio system uses a radio frequency (r.f.) carrier modulated by the amplitude-modulation pulse train.

Principles of PCM transmission systems

- 5.16 Explain that in a PCM system the PAM samples are quantised before transmission.
- 5.17 Describe, with the aid of a diagram, the meaning of quantisation.
- 5.18 Explain the relationship between the number of information bits required in a PCM system and the number of quantisation levels.
- 5.19 Describe, using a sketch, quantisation noise.
- 5.20 Explain the relationship between quantisation noise and bandwidth.
- 5.21 Explain the advantages of non-linear quantisation.
- 5.22 Calculate bandwidth requirements for given PCM systems.
- 5.23 Describe the synchronisation of PCM terminals.
- 5.24 Distinguish between control signals which are
 - i individual to channels
 - ii common to the whole system.
- 5.25 Define the terms 'frame' and 'multiframe' and sketch a typical arrangement showing time scales.
- 5.26 Show that the structure of a multiframe permits the transmission of data signals in addition to encoded speech.

- 5.27 Illustrate by means of a simple block diagram, the principle of encoding and decoding speech.
- 5.28 Explain the main advantages of PCM transmission systems.
Advantages: independence of transmission quality on distance, increased call-carrying capacity of an existing cable network, utilisation of the same transmission path for different services (eg audio, video and data), the effective use of transmission paths having low signal/noise ratios
- 5.29 Describe, with the aid of a simple diagram, the structure of the existing Plesiochronous Digital Hierarchy (PDH).
- 5.30 Describe, with the aid of a simple diagram, the structure of the Synchronous Digital Hierarchy (SDH).

Principles of operation of a 30-channel PCM transmission system

- 5.31 Sketch and label a block diagram showing a 30-channel PCM multiplexer and demultiplexer system.
- 5.32 Use the diagram in 5.31 to identify and describe the functions of
- i channel sampling gates
 - ii speech encoders and decoders
 - iii signalling and synchronisation insertion and extraction
 - iv system clocks.
- 5.33 Sketch a block diagram of a PCM regenerator and include typical voltage waveforms to illustrate the regeneration process.

013 Fundamentals of Electronic Communication 3

06 Access network and digital telephone exchanges

Introduction

The aim of this section is to enable the candidate to understand

- a the evolution of switching systems from analogue to digital
- b the nature of telephone traffic and the implications on network design
- c the fundamentals of major switching systems deployed in telecommunications networks
- d the advantages offered by the digital switching hierarchy
- e access networks and the technologies employed to provide digital line systems.

Notes:

- 1 It is suggested that about 30 guided learning hours should be given to this section.

Book list

Audio, Video and Data Telecommunications; David Peterson.
Telephone Switching Systems; Richard A. Thompson.

Practical competences

The candidate must be able to do the following:

- 6.1 Investigate the necessary elements required for the connection of two local-battery telephones interconnected by a line. Elements are to include telephone circuits with a simple arrangement involving a transmitter, receiver, battery, induction coil, cradle switch, calling generator and alerting bell circuit.
- 6.2 Investigate the reasons for the evolution in voice switching technologies in the Public Switched Telecommunications Network (PSTN) and describe the basic operation of the switching technologies.
Technologies: electromechanical two-motion (Strowger), crossbar, electronic, digital
- 6.3 Investigate how different types of calls are routed across the digital exchange hierarchy and the precautions taken to minimise service disruptions.
Types of calls: local, national, international
Hierarchy: international gateway (class 1 office), national tandem (class 2 office), regional tandem (class 3 office), local tandem (class 4 office), local exchange (class 5 office)

- 6.4 Evaluate the basic functions of the main software and hardware systems used to switch and control call connections in digital exchanges.

Systems: Digital Switching Subsystem (DSS), Management Statistics Subsystem (MSS), Man Machine Interface Subsystem (MMIS), Digital Subscriber Switching Subsystem (DSSS), Maintenance Control Subsystem (MCS), Processor Utility Subsystem (PUS), Test Network Subsystem (TNS), Call Processing Subsystem (CPS), Message Transmission Subsystem (MTS), Network Synchronisation Subsystem (NSS), Automatic Announcement Subsystem (AAS)

Knowledge requirements

The instructor must ensure the candidate is able to:

Principles of telephone instruments

- 6.5 Identify and describe the circuit elements of a telephone instrument sufficient to show the principles of transmitting and receiving.
- 6.6 Explain the meaning of 'sidetone'.
- 6.7 List the disadvantages of excessive sidetone and of no sidetone.
- 6.8 Describe how sidetone is reduced to an acceptable level.
- 6.9 Explain the purpose of the regulator in a telephone instrument.
- 6.10 Describe the principles and advantages of central-battery working.
- 6.11 Explain the need for switching in telecommunication networks.
- 6.12 Explain that the number of links required to fully interconnect n users is given by the formula:
$$l = \frac{1}{2} [n(n-1)]$$
where l is the number of links required to connect n users.
- 6.13 Explain why the PSTN is an example of a circuit-switched network.
- 6.14 Describe, with the aid of diagrams, how signals are detected by the telephone instrument or exchange equipment in electronic exchange systems.
Signals: calling signal, dial pulses, keypad pulses, multifrequency keypad signals, ringing, called subscriber answer, clear-down
- 6.15 Explain the numbering schemes for local, national, and international calls.

- 6.16 Describe value added exchange services.
Services: call diversion, call-back, hold call, three-party conversation etc.
- 6.17 Explain the meaning of the term 'telephone traffic' and its effect on switching.
- 6.18 Define the Erlang as the unit of traffic intensity.
- 6.19 Describe, with the aid of sketches, typical graphs of telephone traffic intensity against time over a 24hour period for both national and international exchanges.
- 6.20 Explain that the intensity of traffic in, Erlangs, is equal to
- i the average number of simultaneous calls in progress
 - ii the average number of calls carried during a period equal to the average holding time of calls
- $$A = \frac{c * t}{T}$$
- where A is the traffic intensity
 - c is the number of calls
 - t is the average duration of call
 - T is the period of measurement.
- 6.21 Perform calculations using the formula in 6.20
- 6.22 Describe the terms 'traffic offered', 'traffic carried', 'traffic lost' and 'busy hour'.
- 6.23 Define grades of service as the ratio of traffic lost to traffic offered, or the probability of blocking.
- 6.24 Perform calculations of grades of service.
- 6.25 Explain that the Erlang is a statement of probability of occupation of a circuit.
- 6.26 Describe how congestion probabilities for a given level of traffic during the busy hour affect the amount of plant required.
- 6.27 Calculate congestion probabilities using Erlang B-distribution and use these values to calculate the corresponding amount of plant.
- 6.28 Determine, using the Erlang B-distribution, that above a particular traffic level the number of crosspoints in a matrix is determined by the required overload performance rather than the traffic level.

Stored program control for common control exchanges

- 6.29 Explain that control of calls can be made by the use of a computer-type system known as Stored Program Control (SPC).
- 6.30 Describe the meaning of SPC.
- 6.31 Explain that, on the origination of a call, the calling circuit is associated with SPC equipment.
- 6.32 Draw a block diagram of the main elements of SPC equipment.
- 6.33 Draw and explain a simple node transition diagram (flowchart) to explain the action of the SPC equipment in setting up an own-exchange call.

Access networks

- 6.34 Describe the physical components of the access network.
Components: copper twisted wire cables, poles, primary and secondary connection points, joint boxes, cable ducting, Main Distribution Frame (MDF), leased lines
- 6.35 Detail the transmission constraints and liabilities associated with copper twisted wire cables.
Constraints and liabilities: ingress of moisture, size, attenuation, bandwidth, susceptibility to faults
- 6.36 Describe the basic operation of technologies utilised in the access network to provide digital transmission capability.
Technologies: Integrated Services Digital Network (ISDN), Asymmetric Digital Subscribers Line (ADSL), modem
- 6.37 Describe how the operations involved in setting up a connection across a digital exchange, using time-space-time switching.
Operations: Digital Line Termination (DLT), Time SWitch (TSW), multiplexing, Cross Office Slot (XOS), receive and transmit stores, Space SWitch (SSW)
- 6.38 Describe the main services offered by digital exchanges and digital Private Automatic Branch EXchanges (PABX).
Services: call diversion, call back, hold, three-party, extension status, night service, executive intrusion, route optimisation, forced release, statistics, co-located PABX and/or Centrex

Assessment

Test specification for written paper Fundamentals of Electronic Communication 3 (2730-02-013)

This is a written examination paper lasting three hours with ten questions. Candidates must answer **all** questions.

The examination will cover the knowledge specifications:

Topic	Approximate % examination weighting
01 Stabilised power supplies	10
02 Optical fibre systems	12
03 Modulation	16
04 Digital transmission and multiplexing	16
05 Pulse modulation and Time Division Multiplex (TDM) systems	22
06 Access networks and digital telephone exchanges	24

014 Communication Systems and Digital Networks 3

01 Structured cabling

Introduction

The aim of this section is to enable the candidate to understand

- a the importance of cabling in the overall framework of data communication
- b the existence of international cabling standards and the benefits of adhering to them
- c how cabling installation practices affect the performance of cabling infrastructure.

Notes:

- 1 It is suggested that about 15 guided learning hours should be given to this section.

Book list

International Standard ISO/IEC 11801:2000 Telecommunication Cabling Installation; BICSI. The Complete Guide to Network Wiring; David Groth and Jim McBee.

Practical competences

The candidate must be able to do the following:

- 1.1 Sketch a diagram illustrating a cabling design. The design must comply with International Standards Organisation/International Electrotechnical Commission (ISO/IEC) 11801 standards.
- 1.2 Interpret link test results and compare with the relevant worst-case performance specifications.
- 1.3 Propose a standards based cabling solution based on a building plan.
- 1.4 Perform literature or Web search for information on evolving cabling standards.
- 1.5 Identify, make up and test typical network cables – fitting suitable connectors (eg RJ45).

Knowledge requirements

The instructor must ensure the candidate is able to:

- 1.6 Explain the meaning of the term 'structured cabling' in the context of commercial premises cabling for data communication.
- 1.7 State that the ISO/IEC 11801 is a standard for generic commercial premises cabling.
Generic: not application specific

- 1.8 Explain what the ISO/IEC 11801 standard states and give reasons why the standard was formulated.
Reasons: voice/data applications support-now and future, multiproduct, multivendor, ease of moves and changes, generic
- 1.9 List the elements that make up the generic cabling system and describe their function.
Elements: campus, building, horizontal cabling, telecommunications outlet, telecommunications closet and equipment room
- 1.10 Demonstrate familiarity with generic cabling terminology and their meanings as used in the ISO/IEC 11801 standard.
Terminology: Floor Distributor (FD), Building Distributor (BD), Campus Distributor (CD), Telecommunication Outlet (TO), Transition Point (TP)
- 1.11 Demonstrate knowledge of different media types recognised by the ISO/IEC 11801 standard.
Media types: 4-pair (or 2-pair) 100 Ω (or 120 Ω) balanced cable, 62.5/125 μm (or 50/125 μm) optical fibre, 2-pair 150 Ω Shielded Twisted Pair (STP), single mode optical fibre
- 1.12 Understand that different building pathways require a different type of cable.
Different: plenum cable requires higher fire rating
- 1.13 Demonstrate an understanding of cable performance terminology.
Terminology: bandwidth, propagation delay, delay skew, attenuation, Attenuation-to-Crosstalk Ratio (ACR)
- 1.14 Describe some installation practices as stipulated by the ISO/IEC 11801 standard.
- 1.15 Describe link performance and state that link performance components and cables are defined as categories but that the link is defined as falling into one of the defined classes.
Categories: 3, 5, 5e, 6
Classes: A, B, C, D, E, F
- 1.16 Explain the importance of conformance testing of installed cabling.
- 1.17 Understand that testing is accomplished using calibrated test equipment that conforms to the cabling test equipment standard.
Standards: ISO/IEC 14763-3 and 61935-1
- 1.18 List parameters that are tested in link performance tests and explain their meaning.
Parameters: Near End Crosstalk (NEXT), Far End Crosstalk (FEXT), Equal Level Far End Crosstalk (ELFEXT), Power Sum Next (PSNEXT), return loss
- 1.19 Understand the importance of properly documenting the installed network in accordance with the guidelines outlined in the ISO/IEC 14763-1 standard.

014 Communication Systems and Digital Networks 3

02 Local Area Networks (LANs), Metropolitan Area Networks (MANs) and Wide Area Networks (WANs)

Introduction

The aim of this section is to enable the candidate to

- a understand the basic concepts of LANs, MANs and WANs
- b compare and contrast the different technologies used to implement LANs, MANs and WANs.

Notes:

- 1 It is suggested that about 20 guided learning hours should be given to this section.

Book list

Building a Network: How to Specify, Design, Procure, and Install a Corporate LAN; Peter D. Rhodes.
Data & Computer Communications (6th edition); William Stallings.
A Guide to Designing and Implementing Local and Wide Area Networks; Michael J. Palmer and Bruce Sinclair.
Introduction to Data Communications and Networking; Behrouz Forouzan, Catherine Ann Coombs, Sophia Chung Fegan.

Practical competences

The candidate must be able to do the following:

- 2.1 Conduct a literature or Web research of network equipment products.
- 2.2 Use a network simulator to investigate LAN activity in a given scenario.
Network simulator: Cnet, Opnet
Activity: traffic flow, protocol comparison, troubleshoot
- 2.3 Construct two LANs and establish a link between them utilising WAN technologies.
- 2.4 Calculate bandwidth requirements for a given LAN design.
- 2.5 Implement backup procedures.
- 2.6 Implement changes to a small LAN.
- 2.7 Recognise peer-to-peer and client-server configurations.

Knowledge requirements

The instructor must ensure the candidate is able to:

- 2.8 Define the terms LAN, MAN and WAN.
- 2.9 Explain the difference between broadcast-media-access and non-broadcast-media-access technologies.
- 2.10 State the various shared media LAN technologies in use today and their operating speeds.
Technologies: Ethernet, token ring, Fibre Distributed Data Interface (FDDI), fast Ethernet, gigabit Ethernet

- 2.11 Describe how Ethernet and token ring technologies work and explain the terms half and full duplex.
- 2.12 Describe LAN topologies.
Topologies: bus, tree, ring and star, extended star
- 2.13 Describe the role of hubs, switches, routers and Network Interface Cards (NICs) in a LAN.
- 2.14 Reference the International Standards Organisation (ISO)/Open System Interconnect (OSI) model and explain at which layers the equipment in 2.13 operate.
Layers: data link, network
- 2.15 Explain the cause and effect of congestion on a network.
Cause: increased traffic, high demand for access
Effect: increased collisions, slow response, time-outs
- 2.16 List factors that will reduce the total throughput of data within a LAN or reduce the bandwidth available for each individual node.
Factors: Ethernet collisions, high volume of users, broadcast storms, inadequate physical segmentation, increased traffic, data backup procedures, faulty cabling, Electro Magnetic Interference (EMI)
- 2.17 Identify the different transmission media deployed in LANs.
Media: Shielded Twisted Pair (STP), Unshielded Twisted Pair (UTP), coaxial cable, optical fibre, wireless
- 2.18 State typical areas covered by LANs.
Typical areas: a company site, a home, an office
- 2.19 State that a network, which serves multiple sites within a city's limits or a metropolitan boundary, would be referred to as a MAN.
- 2.20 Identify the technologies used to implement MANs.
Technologies: line-of-sight microwave, Synchronous Digital Hierarchy (SDH), leased line
- 2.21 State the technologies used in implementing WANs.
Technologies: Frame Relay, Asynchronous Transfer Mode (ATM)
- 2.22 Provide examples of MANs.
Examples: university campus, local government offices
- 2.23 Provide examples of a WAN.
Examples: a company operating networked offices in Tokyo and Osaka, an international company with offices in several countries
- 2.24 Explain the Institute of Electrical and Electronic Engineers (IEEE) 802 standards for LAN access control.
Standards: 802.3 Carrier Sensing Multiple Access/ Collision Detection (CSMA/CD), Medium Access Control (MAC)

014 Communication Systems and Digital Networks 3

03 Transmission systems

Introduction

The aim of this section is to enable the candidate to understand

- a the different transmission media available
- b why optical fibre is replacing coaxial cable on long haul networks
- c the various digital carrier systems in use today
- d data multiplexing methods for utilising bandwidth.

Notes:

- 1 It is suggested that about 20 guided learning hours should be given to this section.

Book list

SONET/SDH Demystified; Steven Shepard.

Practical competences

The candidate must be able to do the following:

- 3.1 Produce a report investigating the use of Dense Wavelength Division Multiplexing (DWDM) techniques.
- 3.2 Conduct Web and literature review on ITU-T standards on Synchronous Digital Hierarchies (SDH) and American National Standards Institute (ANSI) Synchronous Optical Network (SONET) standards.
- 3.3 Draw a diagram illustrating the SDH system.

Knowledge requirements

The instructor must ensure the candidate is able to:

- 3.4 Describe the different data transmission media currently in use.
Media: twisted pair, coaxial cable, optical fibre, radio
- 3.5 Explain the data carrying capacity provided by optical fibre and the potential that exists when Wavelength Division Multiplexing (WDM) is used.
- 3.6 Explain that transmission systems need to be reliable, resilient and flexible because they serve many customers.
- 3.7 Briefly explain the meaning of the terms 'synchronous', 'asynchronous' and 'plesiochronous' signals.
- 3.8 Explain the basic operating principles of synchronous time division multiplexing and statistical time division multiplexing.
- 3.9 Describe the digital carrier systems in use today.

- 3.10 Explain Plesiochronous Digital Hierarchy (PDH) (ITU-T G.702) systems and highlight their disadvantages.
- 3.11 Briefly explain what SONET and SDH are and what necessitated their development.
- 3.12 Describe types of traffic that can be transported over SONET/SDH.
Traffic: voice, IP packets, ATM cells
- 3.13 Describe the operation of add/drop multiplexers.
- 3.14 Describe how the various classes of PDH traffic can be transported by the level one Synchronous Transport Module (STM-1).
PDH traffic: 1.5, 2, 6, 34, 45 and 140 Mbps
- 3.15 Explain the function of virtual containers in the SDH multiplex system.
- 3.16 Describe the structure of the ITU-T G.707 SDH model.
Structure: STM-1 = 155.52 Mbps, STM-4 = 622.08 Mbps, STM-8 = 1.2416 Gbps, STM-12 = 1.86624, STM-16 = 2.48832 Gbps etc.

014 Communication Systems and Digital Networks 3

04 End systems

Introduction

The aim of this section is to enable the candidate to

- a develop an awareness of systems, which are positioned at the end of networks
- b appreciate ergonomics and user-friendly man machine interfaces for computer equipment and networked devices
- c select appropriate hardware for a given need.

Notes:

- 1 It is suggested that about 10 guided learning hours should be given to this section.

Book list

Practical Network Design, Management and Troubleshooting;
J. Scott Haugdahl.

Top-down Network Design; Priscilla Oppenheimer.

Practical competences

The candidate must be able to do the following:

- 4.1 Identify parameters that determine the suitability of one end system over another.
Parameters: total cost of ownership, reliability, compatibility, vendor loyalties, political correctness, performance benchmarks
- 4.2 Conduct a literature and Web research on vendor end systems and international standards relating to end systems technologies.

Knowledge requirements

The instructor must ensure the candidate is able to:

- 4.3 Demonstrate a comprehension of the evolution of the technologies, which support end systems.
End systems: telephones, personal computers (PCs), Electronic Point of Sales (EPOSs), Automatic Teller Machines (ATM), printers, entry systems
- 4.4 Identify methods of connecting equipment to a network.
Methods: cable, wireless, infrared, bluetooth
- 4.5 Describe user-friendly systems connected to networks.
User-friendly systems: Graphical User Interface (GUI), touch screens, fingerprint recognition, iris recognition
- 4.6 Compare command line based systems to GUI based systems.
- 4.7 Describe mainframe computer systems.

- 4.8 Identify the main differences and similarities between mainframe and clientserver networks.
- 4.9 Describe client-server computer systems and compare a clientserver computer system to a peer-to-peer computer system.
- 4.10 Explain web-server technologies and identify software which provides web-server services, briefly mentioning server-side and client-side solutions.
Server-side solution: Common Gateway Interface (CGI)
Client-side solution: JavaScript
- 4.11 Explain telephone technologies including Voice Over Internet Protocol (VOIP).
- 4.12 State the advantages of VOIP over conventional telephone systems.
- 4.13 Describe the possible issues which relate to the implementation of VOIP.
Issues: PBX to PBX, total Internet Protocol (IP) solution, integration with legacy systems, Quality of Service (QoS), latency, jitter
- 4.14 Demonstrate an awareness of current and emerging technologies, which relate to endsystems in various fields.
Fields: audio and video signal processing, broadcast systems, surveillance systems, telemetry, flight control
- 4.15 Describe the effect that Information and Communication Technologies (ICTs) have had upon society and the individual.

014 Communication Systems and Digital Networks 3

05 Network management

Introduction

The aim of this section is to enable the candidate to understand

- a general concepts of network management
- b techniques to monitor, control and maintain network traffic
- c methods of network administration
- d network management protocols, Simple Network Management Protocol (SNMP)
- e security issues relating to the performance and general well-being of a network.

Notes:

- 1 It is suggested that about 23 guided learning hours should be given to this section.

Book list

Network Troubleshooting Tools (O'Reilly System Administration); Joseph D. Sloan.
Practical Network Design, Management and Troubleshooting; J. Scott Haugdahl.
Snmp, Snmv2, Snmv3, and Rmon 1 and 2; William Stallings.

Practical competences

The candidate must be able to do the following:

- 5.1 Identify tools, which can be deployed for network management.
- 5.2 Perform essential administrative network tasks.
Tasks: monitor traffic, maintain documentation, optimisation of network
- 5.3 Use software tools to monitor network traffic.
Tools: protocol analysers, network analysers
- 5.4 Interpret results presented by the tools.
Results: collisions, traffic loading, points of failure
- 5.5 Enable management capability of hardware.
- 5.6 Conduct literature and Web search for information relating to network management.

Knowledge requirements

The instructor must ensure the candidate is able to:

- 5.7 Describe the issues that relate to the management of a computer network.
Issues: traffic flow, security, performance monitoring, fault detection, problem solving

- 5.8 Explain that with larger and more complex networks, use of automated management tools becomes imperative.
- 5.9 Define a Network Management System (NMS).
NMS: collection of tools for network monitoring and control
- 5.10 Describe the elements of an NMS.
Elements: management stations, agents, Management Information Base (MIB), network management protocol
- 5.11 Explain the function of MIBs.
Function: a collection of access points with agents, which report to the management station
- 5.12 List and describe the operation of network management protocols.
Protocols: Remote MONitoring (RMON), Simple Network Management Protocol (SNMP)
- 5.13 Describe the reporting mechanism of management protocols.
- 5.14 Explain the differences between RMON and SNMP.
- 5.15 List equipment that can be remotely managed.
Equipment: SNMP compliant hubs, switches, routers, personal computers (PCs), modems, intelligent patch panels
- 5.16 Explain the terms commonly associated with the reliability of systems.
Terms: availability, mean-time-between-failures (mtbf), mean-time-to-repair (mttr), up time, down time, useful life cycle
- 5.17 Calculate the system/network availability given figures for mtbf and mttr.
- 5.18 Explain that management software can remotely alter the operating parameters of hardware, in addition to monitoring the network.
Parameters: Virtual Local Area Network (VLAN) membership, performance thresholds
- 5.19 Cite examples of network management software.
Management software: HP OpenView, Solstice Sunnet Manager (SSM), BMC patrol
- 5.20 Outline the security issues that relate to network management.
Security issues: eavesdropping, intrusion, spoofing, hackers, viruses
- 5.21 Explain why it is important to have a network wide security policy, including measures to counteract attacks in the form of software viruses.

- 5.22 Describe the implications of a compromised network referencing network security issues.
- 5.23 Explain that encryption is an example of a way of countering security threats.
Encryption: scrambling of data so that it is unintelligible to unauthorised parties
- 5.24 Explain the role of antiviral software in the overall framework of network management.

014 Communication Systems and Digital Networks 3

06 Internet Data Centre (IDC)

Introduction

The aim of this section is to enable the candidate to

- a define the basic configuration and operation for an IDC
- b understand the infrastructure necessary for an IDC
- c identify the routine maintenance tasks of an IDC
- d comprehend the security issues which relate to an IDC.

Notes:

- 1 It is suggested that about 17 guided learning hours should be given to this section.

Book list

Enterprise Data Center Design and Methodology; Rob Snevely.

Practical competences

The candidate must be able to do the following:

- 6.1 Identify hardware necessary to operate an IDC.
Hardware: routers, switches, backup devices, access servers, web servers, Uninterrupted Power Supply (UPS)
- 6.2 Conduct a literature and Web research for vendor IDC solutions.

Knowledge requirements

The instructor must ensure the candidate is able to:

- 6.3 Outline services offered by an IDC.
Services: Internet access, connectivity, data storage, co-location
- 6.4 List the considerations for setting up an IDC.
Considerations: infrastructure, management tools, operating systems, operating network hardware, computing hardware
- 6.5 Understand the basics of the technologies used within an IDC operation.
Technologies: modem, Integrated Services Digital Network (ISDN) access, server clustering, load-balancing, data backup systems, fibre channel, traffic shaping
- 6.6 Recognise the importance of taking into account the effect of unplanned downtime on IDC operations during the planning stage.
- 6.7 Recognise security issues within an IDC.
Security issues: confidentiality, virus protection, data protection act, encryption, physical access

- 6.8 List and describe methods of improving security.
Methods: data encryption, high-level physical access control to buildings, antivirus measures
- 6.9 Identify the facilities required by an IDC, which will enable efficient operation.
Facilities: Heat Ventilation Air-Conditioning (HVAC), physical security, fire suppression systems, seismic proof, waterproof, terrorist proof
- 6.10 Realise the advantage of being located near major public and private interconnects, in order to maximise site performance.
Advantage: access to high-speed data links
- 6.11 Explain the function of a network firewall in an IDC.
Firewall: data filtering
- 6.12 Explain the various options for managed hosting offered by an IDC.
Options: virtual Internet Service Provider (ISP), co-hosting
- 6.13 State different customer's access methods to the IDC.
Methods: Public Switched Telephone Network (PSTN), ISDN, x Digital Subscriber Line (xDSL), leased lines
- 6.14 Identify the issues which affect customer connectivity to the Internet.
Issues: bandwidth, user access ratios, traffic congestion
- 6.15 Describe the factors that affect the continuity of services.
Factors: 24-hour management systems, redundancy, managed power supply, multiple backup, off-site data backups

Assessment

Test specification for written paper Communication Systems and Digital Networks 3 (2730-02-014)

This is a written examination paper lasting three hours with ten questions. Candidates must answer **all** questions.

The examination paper will cover the knowledge specifications:

Topic	Approximate % examination weighting
01 Structured cabling	16
02 Local Area Networks (LANs), Metropolitan Area Networks (MANs) and Wide Area Networks (WANs)	20
03 Transmission systems	12
04 End systems	16
05 Network management	20
06 Internet Data Centre (IDC)	16

Practical assignments

Fundamentals of Electronic Communication 2

Assignment 015/1: Boolean circuits and gates

Assignment 015/2: Impedance and decibels

Communication Systems and Digital Networks 2

Assignment 015/3: Data communication

Assignment 015/4: Transmission Control Protocol / Internet Protocol (TCP/IP) – network address configuration

Assignment 015/5: Router configuration, documentation, Transmission Control Protocol / Internet Protocol (TCP/IP) and the Open Systems Interconnect (OSI) layer models

Fundamentals of Electronic Communication 3

Assignment 015/6: Modem design and characteristics

Assignment 015/7: Historical and practical aspects of telephone networks

Communication Systems and Digital Networks 3

Assignment 015/8: Structured Cabling

Assignment 015/9: Designing a Local Area Network (LAN), Metropolitan Area Network (MAN) and Wide Area Network (WAN) solution

Assignment 015/10: Synchronous Optical Network (SONET)

Assignment 015/11: Designing endsystems for a Small to Medium sized Enterprise (SME)

Assignment 015/12: Network management tools

Practical assignment 015/1: Boolean circuits and gates

1 Objective references

2730-02-011: 2.1

2 Preparation

2.1 Location of the test

The training centre or other venue where supervision and appropriate working conditions will be provided.

2.2 Requirements

Answer books.

Handout showing LED circuit and logical gates.

5 volt d.c. supply.

Three 680 ohm resistors.

Six TTL Logic Gates (1 NOR, 2 EXOR, 3 NAND) and 3 LEDs (1 yellow, 1 green, 1 red).

2.3 Instructor notes

The aim of this assignment is to encourage candidates to apply the laws of Boolean algebra and to construct and investigate an electrical circuit consisting of logic gates and Light Emitting Diodes (LEDs).

Candidates must be familiar with setting up simple electrical circuits. The time candidates are given for this task is three hours. All tasks should be completed within the allocated time.

3 Candidates' instructions

- 3.1 The time allowed for this assignment is three hours. The assignment is divided into two parts. You are advised to read the instructions carefully before commencing any work. Ensure that you understand all the practical instructions and follow them precisely. If you are in any doubt ask your instructor.

Part 1

- 3.2 Using the laws of Boolean algebra, verify that the Boolean expression $B \cdot \bar{B} + A \cdot (\bar{A} + B \cdot A)$ simplifies to the expression $A \cdot B$.
- 3.3 Draw a simple switch circuit to represent the original expression given in 3.2, and also a separate switch circuit to represent the simpler expression given in 3.2.
- 3.4 Explain carefully why the operation of the simpler circuit is equivalent to that of the original.

Part 2

- 3.5 Construct the circuit shown in section 6.1, leaving the connection of the d.c. supply unit until the end. Note that R1, R2 and R3 are 680 ohms.
- 3.6 Turn on the supply and record the sequence of colours which occurs on the LEDs, when each of the three inputs (A, B and C) are selected in the order given in the truth table.
- 3.7 Explain how this sequence arises, by completing the blank table in section 6.1. (You may use the truth tables provided for the NOR, EXOR and NAND gates to assist you in this.)
- 3.8 Hand in all documentation to your instructor in the time allocated. Ensure that all your written work is clearly presented.

4 Marking

Part 1

- 4.1 Assignment completed within three hours. ()
- 4.2 Correctly explained simplification of the given Boolean expression. ()
- 4.3 Correctly drawn Boolean switch circuits for the two expressions. []
- 4.4 Concise, correct explanation of the equivalent behaviour of both the original and simplified Boolean circuits. []

Part 2

- 4.5 Correct connection of the LED/gate circuit. []
- 4.6 Correct sequencing behaviour of the LED/gate circuit. ()
- 4.7 Correct explanation of the lighting sequence. []
- 4.8 Documentation handed in to the instructor. []

5 Assignment completion

The candidate will have satisfactorily completed this assignment if successful in all items marked with a [] and at least one of the items marked with a ().
A period of seven days must elapse before an unsuccessful candidate may retake this assignment.

6 Assignment documentation

- 6.1 A, B and C are increasing as shown. Complete the table to find the sequence of lights.
 In case you have forgotten them, truth tables are provided.
 The cathodes of the LEDs go low to turn them on.

A	B	Z
0	0	1
0	1	1
1	0	1
1	1	0

NAND

A	B	Z
0	0	1
0	1	0
1	0	0
1	1	0

NOR

A	B	Z
0	0	0
0	1	1
1	0	1
1	1	0

EXOR

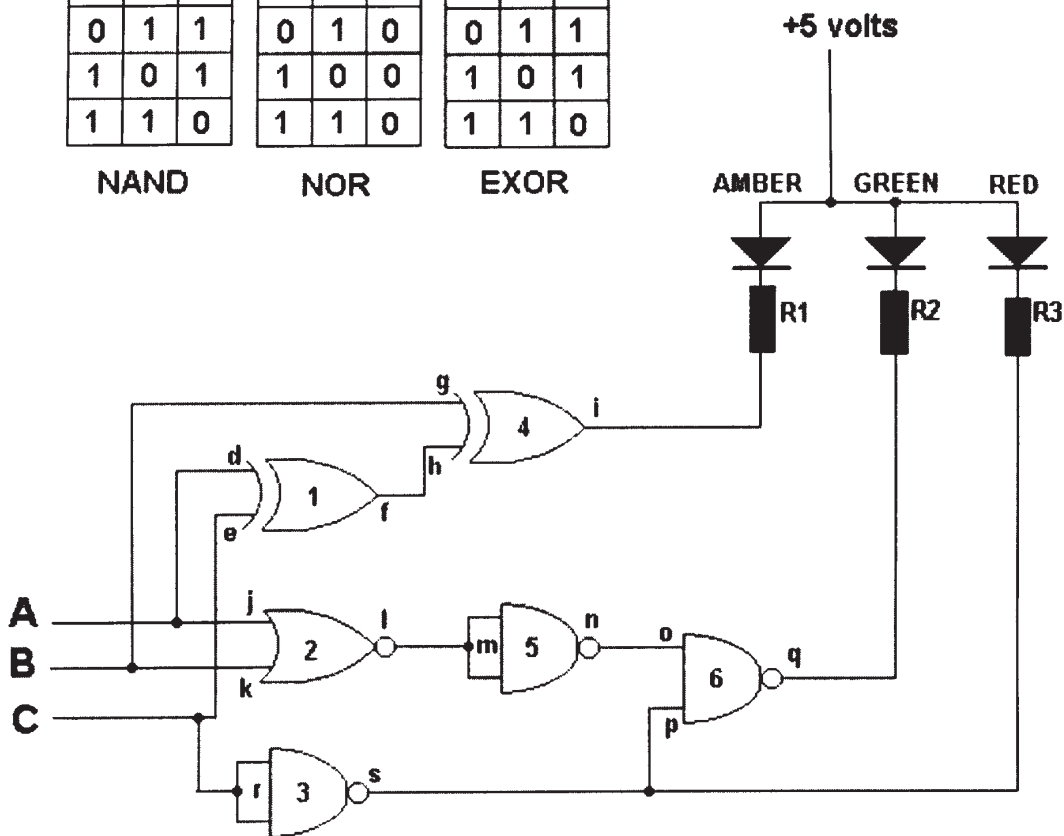

A	B	C	d	e	f	g	h	i	j	k	l	m	n	o	p	q	r	s
0	0	0																
0	0	1																
0	1	1																
1	0	0																

Practical assignment 015/2: Impedance and decibels

1 Objective references

2730-02-011: 5.1

2 Preparation

2.1 Location of the test

The training centre or other venue where supervision and appropriate working conditions will be provided.

2.2 Requirements

Answer books.

Calculator.

2.3 Instructor notes

The aim of this assignment is to encourage candidates to calculate the impedance of a series circuit consisting of Inductance Capacitance and Resistance (LCR), and to calculate the overall voltage gain of a cascade of amplifiers and attenuators.

Candidates must be familiar with the calculation of impedance in a series a.c. circuit.

Candidates should be able to calculate gain and attenuation in decibels and to obtain the gain of a cascaded series combination of amplifiers and attenuators.

The time candidates are given for this task is two hours. All tasks should be completed within the allocated time.

3 Candidates' instructions

- 3.1 The time allowed for this assignment is two hours. The assignment is divided into two parts. You are advised to read the instructions carefully before commencing any work. If you are in any doubt, ask your instructor.
- 3.2 Using the frequency 2 MHz, calculate the inductive reactance, capacitive reactance and hence impedance of an Alternating Current (AC) circuit containing a series combination of a 20 k ohm resistor, a 3.089 mH inductor and a 2.050 pF capacitor.
- 3.3 The impedance you have calculated is the input impedance at the first stage of a cascaded combination of amplifiers and attenuators. An input current of 10 mA is applied to this first stage, which has a voltage gain of 20.

Successive stages have:
A voltage gain of 6 dB.
A voltage gain of 10.
A voltage gain of 11 dB.
A voltage gain of 25.
Finally, a voltage gain of 22 dB.
 - 3.3.1 Draw a fully labelled schematic block diagram of this arrangement.
 - 3.3.2 Calculate the effectively input voltage to the first stage.
 - 3.3.3 Calculate the overall gain of the cascaded combination in decibels.
 - 3.3.4 Confirm your result by converting the stage decibel gains into voltage gains and hence calculating the overall cascade a voltage gain.
 - 3.3.5 Check result of 3.3.4 by converting this to decibels.
 - 3.3.6 Calculate the output voltage from the final stage.
- 3.4 Hand in all documentation to your instructor in the given time allocated.
Ensure that all your written work is clearly presented.

4 Marking

- 4.1 Assignment completed within two hours. ()
- 4.2 Correct calculations of inductive reactance, capacitive reactance and impedance of the series combination at the frequency given. []
- 4.3 Answers for 3.2 applied to cascading amplifiers/attenuators:
 - 4.3.1 Labelled block schematic diagram drawn. ()
 - 4.3.2 Correct calculation of input voltage to first stage. []
 - 4.3.3 Correct calculation of overall gain in decibels. []
 - 4.3.4 Correct calculation of individual voltage gains, and hence overall voltage gain. ()
 - 4.3.5 Conversion check confirms result. ()
 - 4.3.6 Correct calculation of output voltage of final stage. ()
- 4.4 Diagram and calculations handed in to the instructor. []

5 Assignment completion

The candidate will have satisfactorily completed this assignment if successful in all items marked with a [] and at least one of the items marked with a ().

A period of seven days must elapse before an unsuccessful candidate may retake this assignment.

Practical assignment 015/3: Data communication

1 Objective references

2730-02-12: 1.1 – 1.2

2 Preparation

2.1 Location of the test

The training centre or other venue where supervision and appropriate working conditions will be provided.

2.2 Requirements

Writing materials.

Access to a computer with communication software that facilitates terminal emulation.

2.3 Instructor notes

The time candidates are given for this task is three hours. All tasks should be completed within the allocated time.

3 Candidates' instructions

- 3.1 The time allowed for this assignment is three hours. In this assignment you are required to draw and label a diagram. You will also investigate the configuration of a serial communication terminal. You are advised to read the instructions carefully before commencing any work. Ensure that you understand all instructions and follow them precisely. If in any doubt ask your instructor.

Part 1

- 3.2 Draw a block diagram illustrating communication between two computers over a public telephone network. Include and label all the necessary equipment to achieve full bidirectional communication.
- 3.3 Provide a written description of the function of each labelled element of the diagram.

Part 2

- 3.4 On the computer provided, initialise the terminal emulation software. Access the configuration section of the software.
- 3.5 Record the settings of the following parameters:
- 3.5.1 bits per second (bps)
 - 3.5.2 data bits
 - 3.5.3 parity
 - 3.5.4 stop bits
 - 3.5.5 flow control.
- 3.6 List the optional settings and provide a written explanation of the function of at least three of the parameters.
- 3.7 Sign all the documentation and hand it in to your instructor.

4 Marking

4.1 Assignment completed in three hours. ()

Part 1

4.2 Accurate block diagram drawn and labelled. []

4.3 A written description of the function of each labelled element provided. []

Part 2

4.4 Terminal software initialised. Configuration section accessed. []

4.5 Setting of following parameters recorded:

4.5.1 bits per second (bps). ()

4.5.2 data bits. ()

4.5.3 parity. ()

4.5.4 stop bits. ()

4.5.5 flow control. ()

4.6 Settings listed. Written explanation of the function of at least three parameters provided. []

4.7 All documentation handed in to the instructor. []

5 Assignment completion

The candidate will have satisfactorily completed this assignment if successful in all items marked with a [] and at least three of the items marked with a ().

A period of seven days must elapse before an unsuccessful candidate may retake this assignment.

Practical assignment 015/4: Transmission Control Protocol / Internet Protocol (TCP/IP) – network address configuration

1 Objective references

2730-02-012: 3.1 – 3.4

2 Preparation

2.1 Location of the test

The training centre or other venue where supervision and appropriate working conditions will be provided.

2.2 Requirements

Two TCP/IP networked computers and one printer.

Operating system that facilitates network configuration and connectivity.

Internet access may be required to download software or drivers.

2.3 Instructor notes

Candidates may undertake assignments in pairs, provided results analysis is taken independently by each candidate.

Candidates must be familiar in setting up and networking computers.

The time candidates are given for this task is three hours. All tasks should be completed within the allocated time.

3 Candidates' instructions

- 3.1 The time allowed for this assignment is three hours. In this assignment you are required to set up a small computer network using Transmission Control Protocol / Internet Protocol (TCP/IP), to cover three scenarios. You are advised to read the instructions carefully before commencing any work. Ensure that you understand all instructions and follow them precisely. If you are in any doubt ask the instructor.
- 3.2 Switch on both computers.
- 3.3 Take note of the operating system, that is used on each computer.
- 3.4 Establish and record the network identity or the computer name of each computer.
- 3.5 Using a hub or a crossover cable, connect both computers together.
- 3.6 Change the IP address on the first computer to 192.168.0.1 and 192.168.0.2 on the second computer. Apply the subnet mask of 255.255.255.0 to both computers. Reboot if necessary.
- 3.7 Using the ping command, ping the other computer and write down the response. Ensure that both computers did ping successfully.
- 3.8 Change the IP address on both computers to 192.168.0.1. Apply the subnet mask of 255.255.255.0 to both computers. Reboot if necessary.
- 3.9 Connect both computers. Record the response and the reason for the response.
- 3.10 Change the IP address on one computer to 192.168.4.5 using a class B subnet mask 255.255.0.0 and change the IP address on the other computer to 192.168.4.168 and set the subnet mask to 255.255.255.0. Reboot if necessary.
- 3.11 Connect both computers together and try to access the other computer via the network connection. Record the result and state the reason.
- 3.12 Change the subnet mask of the computer with the IP address of 192.168.4.5 from 255.255.0.0 to 255.255.255.0. Both computers should now have a subnet mask of 255.255.255.0. Reboot if necessary.
- 3.13 Connect both computers and try to access the other computer via the network. Record the result and state the reason.

- 3.14 Set the IP address of the first computer to 192.168.4.1 and of the second computer to 192.168.4.2. Change the subnet mask for both computers to 255.255.255.192. Reboot the computers if necessary.
- 3.15 Connect both computers and state whether they can connect via the network.
- 3.16 Set the subnet mask on both computers to 255.255.255.0, reboot computers if necessary and record the response.
- 3.17 Retain the IP address 192.168.4.2 and the subnet mask 255.255.255.192 of the second computer. Record and apply a valid IP-address for the first computer to successfully connect to the second computer.
- 3.18 Print out your work and hand it in to your instructor.

4 Marking

- 4.1 Assignment completed in three hours. ()
- 4.2 Computer switched on. []
- 4.3 Operating systems of both computers recorded. ()
- 4.4 Network identity or computer name recorded. ()
- 4.5 Both computers connected correctly. []
- 4.6 Correct IP-address and subnet masks of both computers applied. []
- 4.7 Both computers successfully pinged and response recorded. []
- 4.8 IP address on computer changed to 192.168.0.1./24. []
- 4.9 Computers connected. Correct response and reason recorded. []
- 4.10 IP addresses correctly changed for second scenario. []
- 4.11 Computers connected and correct response recorded. []
- 4.12 Both computers have a subnet mask of 255.255.255.0 []
- 4.13 Computers connected and correct response and reason recorded. []
- 4.14 IP addresses correctly changed for third scenario. ()
- 4.15 Computers connected and correct response recorded. ()
- 4.16 Subnet mask 255.255.255.0 applied to both computers and correct response recorded. ()
- 4.17 Valid IP address applied and recorded for the first computer. ()
- 4.18 All documents printed out and handed in to the instructor. []

5 Assignment completion

The candidate will have satisfactorily completed this assignment if successful in all items marked with a [] and at least two of the items marked with a ().

A period of seven days must elapse before an unsuccessful candidate may retake this assignment.

Practical assignment 015/5: Router configuration, documentation, Transmission Control Protocol / Internet Protocol (TCP/IP) and the Open Systems Interconnect (OSI) layer models

1 Objective references

2730-02-012: 2.1 – 2.2, 5.1 – 5.3

2 Preparation

2.1 Location of the test

The training centre or other venue where supervision and appropriate working conditions will be provided.

2.2 Requirements

A computer system with printer access for each candidate.

Word processing software.

Internet access or networking products catalogues and configuration instructions.

Copy of section 6.

2.3 Instructor notes

Ensure that the candidates are given access to information about purchasing network equipment. This can be done either by access to the Internet or by supplying manufacturer or dealer catalogues.

The time candidates are given for this task is three hours. All tasks should be completed within the allocated time.

3 Candidates' instructions

3.1 The time allowed for this assignment is three hours. In this assignment you are required to identify network equipment. You are advised to read the instructions carefully before commencing any work. Ensure that you understand all instructions and follow them precisely. If you are in any doubt ask the instructor.

Study carefully the schematic diagram which you have been given by your instructor. On the diagram you will find several networking devices labelled with a number.

3.2 Record each of the labelled device types.

3.3 Record the layer of the Open Systems Interconnect (OSI) reference model at which the device operates.

3.4 Draw circles on the schematic diagram identifying all collision and broadcast domains.

3.5 Create and record a classfull IP addressing scheme that includes the complete IP addresses and subnet mask of all the Ethernet and serial network interfaces. Ensure that your scheme includes all the devices represented in the diagram.

3.6 Determine and record an appropriate routing protocol.

3.7 Determine and record an appropriate encapsulation type.

3.8 Determine and record an appropriate routed protocol.

3.9 Use the Internet to find network equipment manufacturer's product lists and corresponding configuration instructions. Alternatively you could use printed reference material, if available.

3.10 Select one layer 3 device from the diagram and choose a device with at least the same specification from the reference materials. Record the name of the manufacturer, model number and if possible, state the price of the chosen device.

3.11 Create a configuration file that would permit the chosen layer 3 device to meet its role within the network represented in the diagram.

3.12 Print out the completed configuration. Hand in all documentation to your instructor.

4 Marking

- 4.1 Assignment completed within three hours. ()
- 4.2 Labelled device types recorded. ()
- 4.3 Correct OSI layers recorded. []
- 4.4 Collision and broadcast domains identified. []
- 4.5 Complete IP addressing scheme recorded. []
- 4.6 Appropriate routing protocol recorded. ()
- 4.7 Appropriate encapsulation type recorded. ()
- 4.8 Appropriate routed protocol recorded. ()
- 4.9 Reference material found. []
- 4.10 Appropriate device chosen and details recorded. []
- 4.11 Configuration file created. []
- 4.12 Configuration file and documentation handed in. []

5 Assignment completion

The candidate will have satisfactorily completed this assignment if successful in all items marked with a [] and at least three of the items marked with a ().

A period of seven days must elapse before an unsuccessful candidate may retake this assignment

6 Assignment documentation

Schematic diagram

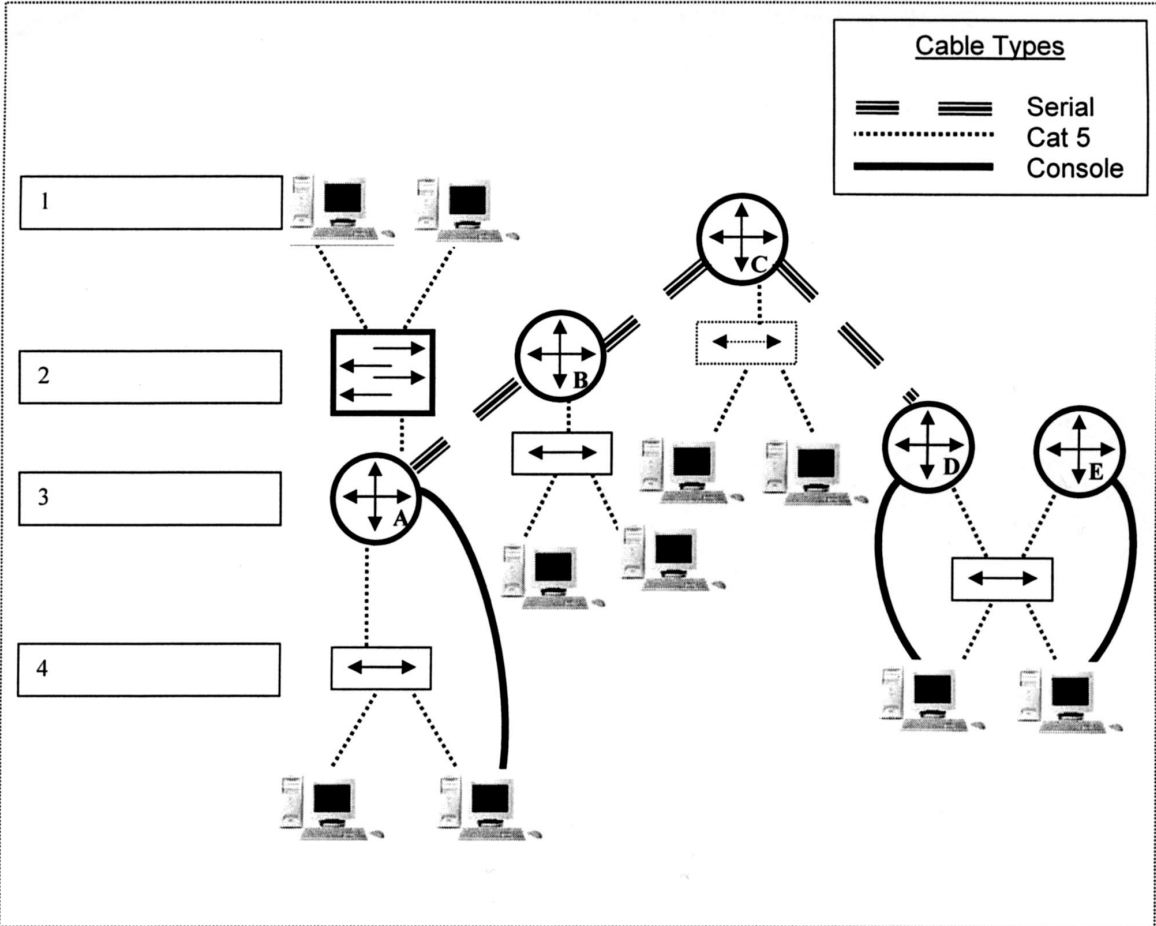

Practical assignment 015/6: Modem design and characteristics

1 Objective references

2730-02-013: 3.1, 4.1

2 Preparation

2.1 Location of the test

The training centre or other venue where supervision and appropriate working conditions will be provided.

2.2 Requirements

External modem with access to an analogue network exchange (internal or external network).

Access to reference sources that contain up to date as well as basic information on modems. Access to the Internet and/or printed manufacturers product lists would ensure a realistic response.

2.3 Instructor notes

The aim of this assignment is to encourage candidates to investigate the design characteristics of modems and analyse the modulation schemes employed for the transfer of data.

Ensure that the candidates are given access to a pair of working modems with connections to internal or external telephone networks. Provide information about modems, this can be done either by access to the Internet or by supplying manufacturer or dealer catalogues.

The time candidates are given for this task is three hours, not including the time needed to write up the report. All tasks should be completed within the allocated time.

3 Candidates' instructions

3.1 The time allowed for this assignment is three hours, not including the time needed to write up your report. In this assignment you are required to investigate the modulation schemes employed for the serial transfer of digital data over analogue networks (eg the PSTN) and to produce a report which covers your findings. You are advised to read the instructions carefully before commencing any work. Ensure that you understand all instructions and follow them precisely. If you are in any doubt ask the instructor.

Part 1

3.2 Construct a modem link and communicate across an analogue network.

3.3 Demonstrate modem interchange light emitting diodes operating during a connection and describe the meaning of the signalling.

Part 2

3.4 Investigate the range of modulation schemes and minimisation techniques employed in modern modems and produce a report that covers:

3.4.1 The need for modems.

3.4.2 The function of the Data Communications Equipment (DCE).

3.4.3 The function of the Data Terminal Equipment (DTE).

3.4.4 The role of the Hayes command set.

3.4.5 The type of communication links established (ie whether synchronous or asynchronous, duplex or half-duplex, symmetric or asymmetric).

3.4.6 The modulation schemes that can be employed for

3.4.6.1 low speed applications

3.4.6.2 medium speed applications

3.4.6.3 high speed applications.

3.7.7 How data transmission speeds in excess of the Shannon-Hartley limit can be achieved.

3.7.8 The ITU-T (formerly CCITT) standards for modems.

3.7.9 The use of cable modems.

3.5 You should access a wide range of reference sources (text and web based) during your investigation.

3.6 Your report should list all sources of reference used.

3.7 Print out your work and hand it in to your instructor before the given deadline.

4 Marking

- 4.1 Assignment completed within three hours (excluding-write up). ()

Part 1

- 4.2 Modem link constructed and successful communication established. ()
- 4.3 Modem interchange light emitting diodes operating during a connection demonstrated and the meaning of the signalling described. ()

Part 2

- 4.4 Report covers:
- 4.4.1 The need for modems. []
 - 4.4.2 The function of the DCE. ()
 - 4.4.3 The function of the DTE. ()
 - 4.4.4 The role of the Hayes command set. ()
 - 4.4.5 The type of communication links established. ()
 - 4.4.6 The modulation schemes that can be employed for
 - 4.4.6.1 low speed applications ()
 - 4.4.6.2 medium speed applications ()
 - 4.4.6.3 high speed applications. ()
 - 4.4.7 Description of how data transmission speeds in excess of the Shannon-Hartley limit can be achieved. ()
 - 4.4.8 The ITU-T standards for modems. ()
 - 4.4.9 The use of cable modems. ()
- 4.5 Wide range of reference sources accessed. ()
- 4.6 All sources of reference have been acknowledged. []
- 4.7 All documentation printed and handed in to the instructor. []

5 Assignment completion

The candidate will have satisfactorily completed this assignment if successful in all items marked with a [] and at least seven of the items marked with a ().

A period of seven days must elapse before an unsuccessful candidate may retake this assignment.

Practical assignments – Fundamentals of Electronic Communication 3

Practical assignment 015/7: Historical and practical aspects of telephone networks

1 Objective references

2730-02-013: 5.1, 6.1-6.4

The time candidates are given for part one of this task is three hours. Additional time for research purposes may be allocated if required. The students will need to spend a considerable amount of their own time in researching parts two and three of the assignment.

2 Preparation

2.1 Location of the test

The training centre or other venue where supervision and appropriate working conditions will be provided.

2.2 Requirements

Basic telephone instruments and components to include:

transmitters, receivers, batteries, induction coils, cradle switches, calling generators, alerting bells and two-wire/four-wire links, terminations, connections, voltmeter.

Access to reference sources that contain up to date as well as historic information on telephone networks and exchanges. Access to the Internet and/or printed manufacturer's product lists would ensure a realistic response.

2.3 Instructor notes

The aim of this assignment is to encourage candidates to investigate the basic elements and historical aspects of telephone networks, to investigate the routing of various types of call and the necessary systems and subsystems required.

The assignment is in three parts.

Part one is expected to be a practical investigation into the telephone instrument and the essential components required to establish voice communication over a line system.

Part two is an investigation into the historical development of telephone networks over the past one hundred and twenty years.

Part three is an investigation into the routing of calls through digital exchanges and the various systems and subsystems required. If desired, this assignment can be offered as three mini assignments distributed evenly over the time taken to deliver the subject.

Ensure that the candidates are given access to the physical resources specified in the resource requirements.

3 Candidates' instructions

This assignment is in three parts. In part one you are expected to carry out a practical investigation into telephone instruments and the essential components required to establish voice communication over line systems. Part two is an investigation into the historical development of telephone networks over the past one hundred and twenty years. Part three is an investigation into the routing of calls through digital exchanges and the various systems and subsystems required.

The time allowed for part one of this assignment is three hours, not including the time to write up your report. You should produce a short report that covers the basic system for linking two telephone instruments and the essential components required to establish voice communication and signalling. Parts two and three of the assignment are research based.

Part two consists of research into the historical aspects of telephone networks and exchange technology whilst in part three you are required to investigate how local, national and international calls are routed across the digital exchange hierarchy and to describe the functions of the main software and hardware systems required. You are required to produce comprehensive written reports that cover your findings for both parts two and three of this assignment. Parts two and three of this assignment should be completed in your own time and handed in to your instructor before the given deadline.

You are advised to read the instructions carefully before commencing any work. Ensure that you understand all instructions and follow them precisely. If you are in any doubt ask the instructor.

Part 1

- 3.1 Construct a simple link between two telephone instruments and establish voice communication and simple signalling (ie use of alerting circuits).
- 3.2 Investigate the components within the telephone instrument. Write a short report that lists the essential components and describes their function in establishing communication between two interconnected telephone instruments.

Part 2

- 3.3 Produce a report which
 - 3.3.1 investigates the historical aspects of developments in the Public Switched Telecommunications Network (PSTN)
 - 3.3.2 provides reasons for the evolution in voice switching technology.

- 3.4 Describe the basic operation of each of the following switching technologies:

- 3.4.1 Strowger.
- 3.4.2 Crossbar.
- 3.4.3 Electronic.
- 3.4.4 Digital (eg system X).

Part 3

- 3.5 Investigate and record how local, national and international calls are routed across the digital exchange hierarchy and the precautions taken to minimise service disruptions. Your investigation should include:
 - 3.5.1 Local exchange (central office/class 5 office).
 - 3.5.2 Local tandem exchange (class 4 office).
 - 3.5.3 Regional tandem exchange (class 3 office).
 - 3.5.4 National tandem exchange (class 2 office).
 - 3.5.5 International gateway.
- 3.6 Evaluate and record the functions of the main software and hardware systems used to switch and control call connections in digital exchanges. Your research should include at least six of the following:
 - 3.6.1 Digital switching subsystem.
 - 3.6.2 Management statistics subsystem.
 - 3.6.3 Man-machine interface subsystem.
 - 3.6.4 Digital subscriber switching.
 - 3.6.5 Maintenance control subsystem.
 - 3.6.6 Processor utility subsystem.
 - 3.6.7 Test network subsystem.
 - 3.6.8 Call processing subsystem.
 - 3.6.9 Message transmission subsystem.
 - 3.6.10 Network synchronisation subsystem.
 - 3.6.11 Automatic announcement subsystem.

- 3.7 You should access a wide range of reference sources (text and web based) during your investigation. Your report should list all sources of reference used.
- 3.8 Hand in your report to your instructor before the given deadline.

4 Marking

Part 1

- Part 1 of the assignment completed within three hours (excluding write-up). ()
- 4.1 Telephone link constructed, voice communication and signalling established. ()
- 4.2 Short report produced, which covers the essential components required for simple voice communication and signalling. []

Part 2

- 4.3 Report produced which includes
 - 4.3.1 an investigation of the historical aspects of the development in the PSTN []
 - 4.3.2 provides reasons for the evolution in voice switching technology. []
- 4.4 Description of each of the following switching technologies provided:
 - 4.4.1 Strowger. ()
 - 4.4.2 Crossbar. ()
 - 4.4.3 Electronic. ()
 - 4.4.4 Digital. ()

Part 3

- 4.5 Investigation recorded and includes:
 - 4.5.1 Local (central office/class 5 office). ()
 - 4.5.2 Local tandem (class 4 office). ()
 - 4.5.3 Regional tandem (class 3 office). ()
 - 4.5.4 National tandem (class 2 office). ()
 - 4.5.5 International gateway. ()

- 4.6 Evaluation recorded and includes at least six of the following:
- 4.6.1 Digital switching subsystem. ()
 - 4.6.2 Management statistics subsystem. ()
 - 4.6.3 Man-machine interface subsystem. ()
 - 4.6.4 Digital subscriber switching. ()
 - 4.6.5 Maintenance control subsystem. ()
 - 4.6.6 Processor utility subsystem. ()
 - 4.6.7 Test network subsystem. ()
 - 4.6.8 Call processing subsystem. ()
 - 4.6.9 Message transmission subsystem. ()
 - 4.6.10 Network synchronisation subsystem. ()
 - 4.6.11 Automatic announcement subsystem. ()
- 4.7 Clearly cross-referenced all sources of reference used. []
- 4.8 All documentation printed and handed in to the instructor. []

5 Assignment completion

The candidate will have satisfactorily completed this assignment if successful in all items marked with a [] and at least 12 of the items marked with a ().

A period of seven days must elapse before an unsuccessful candidate may retake this assignment.

Practical assignment 015/8: Structured cabling

1 Objective references

2730-02-014: 1.1 – 1.5

2 Preparation

2.1 Location of the test

The training centre or other venue where supervision and appropriate working conditions will be provided.

2.2 Requirements

Writing and drawing materials.

Access to computers, printers and the Internet.

Simple building floor plans (drawn to scale).

Samples of different network cables.

Lengths of typical network cables.

Typical connectors.

Terminating tools eg crimp.

Test equipment (eg continuity tester).

2.3 Instructor notes

The time candidates are given to complete this task is three hours. All tasks should be completed within the allocated time.

Candidates require a building floor plan, which is drawn to a scale.

The plan must clearly indicate the scale along with any services, such as water pipes or electricity supply cables.

The plan should represent a building that exceeds 200 meters in length and 100 meters in depth and include services (electricity cables, water and gas pipes etc.).

Candidates' submissions should show that they have applied standards to their cabling design and clearly identify which standards they have applied.

Candidates should correctly identify sample network cables and make up, terminate and test a length of typical network cable, to be provided by the instructor.

3 Candidates' instructions

- 3.1 The time allowed for this assignment is three hours. In this assignment you are required to prepare from a building plan, a cabling design which adheres to the latest version of cabling standard, International Standards Organisation / International Electrotechnical Commissions (ISO/IEC) 11801. You are advised to study carefully the plan before you commence your work. If you are in any doubt ask the instructor.
- 3.2 Draw your proposed cabling design on the plan provided.
- 3.3 Create a legend to identify all the components you have drawn. Ensure that you use the correct labelling and cabling terminology.
- 3.4 Write a report identifying the methods and equipment you would use to test the proposed installation. Ensure that your report references and complies with international cabling standards and would meet industry certification criteria. Use the Internet to find the current ISO/IEC standards. Alternatively you could use printed reference material, if available.
- 3.5 Identify network cables from the samples provided.
- 3.6 Make up and terminate network cables.
- 3.7 Test the completed cable and ensure fitness for purpose.
- 3.8 Sign all documentation and hand it in to your instructor.

4 Marking

- | | | |
|-----|----------------------------------------------------------|-----|
| 4.1 | Assignment completed in three hours. | () |
| 4.2 | Cabling design drawn. | [] |
| 4.3 | Legend created. | [] |
| 4.4 | Methods and equipment identified. Report written. | () |
| 4.5 | Network cables identified. | () |
| 4.6 | Network cables made up and terminated. | () |
| 4.7 | Completed cable tested and fitness for purpose ensured. | [] |
| 4.8 | All documentation signed and handed into the instructor. | [] |

5 Assignment completion

The candidate will have satisfactorily completed the assignment if successful in all items marked with a [] and at least 2 items marked with ().

A period of seven days must elapse before an unsuccessful candidate may retake this assignment.

Practical assignments – Communication Systems and Digital Networks 3

Practical assignment 015/9: Designing a Local Area Network (LAN), Metropolitan Area Network (MAN) and Wide Area Network (WAN) solution

1 Objective references

2730-02-14: 2.1 – 2.7

2 Preparation

2.1 Location of the test

The training centre or other venue where supervision and appropriate working conditions will be provided.

2.2 Requirements

Computer.

Printer.

Word processing software.

Internet access or networking product catalogues.

A documented local office scenario that consists of 20 standalone PCs.

2.3 Instructor notes

Ensure that the candidates are given access to information about purchasing networking equipment. This can be done either by access to the Internet or by supplying manufacturer or dealer catalogues.

Produce a scenario of a typical company for the locality of the candidate, in which the office has only 20 standalone Personal Computers (PCs). The office infrastructure is to be upgraded to include LAN, MAN and WAN technologies meeting the following criteria:

- The company intends to expand and the office is expected to grow to twice its size in the near future.
- The company requires the implementation of a paperless office systems where ever possible.
- A system for central data storage and central data control is required.
- Internet access is required ensuring that the local network is protected from unauthorised access.
- The company has one branch overseas which needs to be connected to the local network.
- There is another office two kilometres away which has already been networked and needs to be connected to the new networked office.

The time candidates are given for this task is three hours. All tasks should be completed within the allocated time. The presentation can be done in another class session.

3 Candidates' instructions

- 3.1 The time allowed for this assignment is three hours, not including the time needed to write up your presentation document. In this assignment you are required to produce a network solution for an office, which is equipped with 20 standalone computers. You are advised to read the instructions carefully before commencing any work. Ensure that you understand all instructions and follow them precisely. If you are in any doubt ask the instructor.
- 3.2 Study carefully the scenario provided by your instructor and compile a list of at least five items needed to set up the Local Area Network (LAN).
- 3.3 Compile a list of at least two items needed to set up the Metropolitan Area Network (MAN).
- 3.4 Compile a list of at least two items needed to set up the Wide Area Network (WAN).
- 3.5 Briefly state the minimum specification for the items you have listed for each network type.
- 3.6 Using the catalogues provided or the Internet, obtain model numbers, manufacturer details and prices for the selected items.
- 3.7 State whether your solution includes a client server network or a peer-to-peer network for the LAN and provide a reason for your choice.
- 3.8 Describe the backup procedures and equipment used for your solution.
- 3.9 Briefly describe the methods of connecting to the office overseas and to the other office two kilometres away.
- 3.10 Produce a plan to implement the change to the office to ensure least disruption to the normal office activity.
- 3.11 Discuss bandwidth requirements and methods to conserve and optimise bandwidth on the network.
- 3.12 Produce a document, which can be used for a presentation outlining your solution for the office.
- 3.13 Present your solution to the class (the presentation should last between five and ten minutes).
- 3.14 Print out your work and hand it in to your instructor.

4 Marking

- 4.1 Assignment completed within three hours (excluding write up). ()
- 4.2 List for LAN equipment (at least five items). ()
- 4.3 List for MAN equipment (at least two items). ()
- 4.4 List for WAN equipment (at least two items). ()
- 4.5 Minimum specifications for all items stated. ()
- 4.6 Model numbers, manufacturers details and prices obtained. ()
- 4.7 Reason for chosen network type stated. []
- 4.8 Backup procedures and equipment described. ()
- 4.9 Methods for connecting the remote offices described. []
- 4.10 Plan for implementing change has been produced. ()
- 4.11 Bandwidth requirements discussed. ()
- 4.12 Presentation document produced. []
- 4.13 Solution presented to the class. ()
- 4.14 All documentation printed and handed in to the instructor. []

5 Assignment completion

The candidate will have satisfactorily completed this assignment if successful in all items marked with a [] and at least seven of the items marked with a (). A period of seven days must elapse before an unsuccessful candidate may retake this assignment.

Practical assignment – Communication Systems and Digital Networks 3

Practical assignment 015/10: Synchronous Optical Network (SONET)

1 Objective references

2730-02-014: 3.1 – 3.3

2 Preparation

2.1 Location of the test

The training centre or other venue where supervision and appropriate working conditions will be provided.

2.2 Requirements

Access to a range of reference sources for SONET/SDM (paper based and CD Rom/web based) and appropriate textbooks.

Pen, pencil, ruler, paper.

2.3 Instructor notes

The aim of this assignment is to encourage candidates to investigate the SDH/SONET systems.

The research and writing up of Part 2 of this assignment may be done outside the three hour practical session.

3 Candidates' instructions

3.1 The time allowed for this task is three hours not including the time needed to finish your research and write the report in Part 2. In this assignment you are required to draw the SONET system hierarchy and the SONET multiplexing hierarchy. You are advised to read all the instructions before commencing any work. If you have any doubt ask the instructor.

Part 1

3.2 Draw the SONET system hierarchy and the SONET multiplexing hierarchy. Label all the components accurately and clearly.

Part 2

3.3 Produce a short report explaining the multiplexing principles of SONET. Your report should include:

3.3.1 Mapping, multiplexing, stuffing and six of the following ten points:

3.3.2 SONET network elements

- Terminal multiplexers.
- Regenerators.
- Add/Drop Multiplexers (ADM).
- Wide band digital cross-connectors.
- Broadband digital cross-connectors.
- Digital loop carrier.

3.3.3 SONET network configurations

- Point-to-point.
- Point-to-multipoint.
- Hub network.
- Ring architecture.

3.4 Hand your diagram and report in to your instructor.

4 Marking

4.1 Assignment completed in three hours. ()

Part 1

4.2 Diagram drawn and labelled. []

Part 2

4.3 Report produced including:

4.3.1 Mapping, multiplexing, stuffing and six of the following ten points: []

4.3.2 SONET network elements

- Terminal multiplexers. ()
- Regenerators. ()
- Add/Drop Multiplexers (ADM). ()
- Wide band digital cross-connectors. ()
- Broadband digital cross-connectors. ()
- Digital loop carrier. ()

4.3.3 SONET network configurations

- Point-to-point. ()
- Point-to-multipoint. ()
- Hub network. ()
- Ring architecture. ()

4.4 Diagram and report handed in to the instructor. []

5 Assignment completion

The candidate will have satisfactorily completed this assignment if successful in all items marked with a [] and at least six of the items marked with ().

A period of seven days must elapse before an unsuccessful candidate may retake this assignment.

Practical assignment 015/11: Designing endsystems for a Small to Medium sized Enterprise (SME)

1 Objective references

2730-02-014: 4.1 – 4.2

2 Preparation

2.1 Location of the test

The training centre or other venue where supervision and appropriate functioning equipment and working conditions will be provided.

2.2 Requirements

Computer system.

Printer.

Appropriate software to produce documents.

Internet access or network equipment catalogues.

A given scenario for a local SME.

2.3 Instructor notes

Produce a scenario describing an SME typical for the locality of the candidate, which needs to use the following equipment: workstations, server, simple network infrastructure, EPOS, PBX, telephones, monitors

Ensure that the candidates are given access to information about purchasing endsystems equipment. This can be done either by access to the Internet or by supplying manufacturer or dealer catalogues.

The time candidates are given for this task is three hours. All tasks should be completed within the allocated time. The presentation can be done in another class session.

3 Candidates' instructions

- 3.1 The time allowed for this assignment is three hours, not including the time needed to write up your presentation document. In this assignment you are required to analyse the needs of a Small to Medium Sized Enterprise (SME). You are advised to read the instructions carefully before commencing any work. Ensure that you understand all instructions and follow them precisely. If you are in any doubt ask the instructor.
- 3.2 Study carefully, the scenario provided by your instructor.
- 3.3 Compile a list of at least five items needed by the SME described in the scenario.
- 3.4 Briefly list the minimum specification for the items you have listed.
- 3.5 Using the catalogues provided or the Internet, obtain model numbers, manufacturer details and prices for the selected items.
- 3.6 Produce a document which can be used for a short presentation, outlining your solution for the SME.
- 3.7 Present your solution to the class (the presentation should last between five and ten minutes).
- 3.8 Print out your work and hand it in to your instructor.

4 Marking

- 4.1 Assignment completed in three hours. ()
- 4.2 List compiled, at least five different items identified. []
- 4.3 Minimum specifications for all listed items stated. []
- 4.4 Model numbers, manufacturer details and prices obtained. ()
- 4.5 A short document produced for presentation. ()
- 4.6 Solution presented to the class. ()
- 4.7 All documentation printed and handed in to the instructor. []

5 Assignment completion

The candidate will have satisfactorily completed this assignment if successful in all items marked with a [] and at least two of the items marked with a ().

A period of seven days must elapse before an unsuccessful candidate may retake this assignment.

Practical assignment 015/12: Network management tools

1 Objective references

2730-02-014: 5.1 – 5.6

2 Preparation

2.1 Location of the test

The training centre or other venue where supervision and appropriate working conditions will be provided.

2.2 Requirements

Two computer systems with printer access for each candidate or pair of candidates who is/are to be assessed.

Appropriate software, which can be used to analyse protocols and network traffic.

Operating system that facilitates network configuration and connectivity.

Internet access for software downloads.

Network facilities to connect both computers using Ethernet.

2.3 Instructor notes

Candidates may undertake the assignments in pairs, provided results analysis is taken independently by each candidate.

Candidates must be familiar in setting up and networking computers.

The time candidates are given for this task is three hours. All tasks should be completed within the allocated time.

3 Candidates' instructions

- 3.1 The time allowed for this assignment is three hours. In this assignment you are required to set up a small computer network to utilise network monitoring and managing software. You are advised to read the instructions carefully before commencing any work. Ensure that you understand all instructions and follow them precisely. If you are in any doubt ask the instructor.
- 3.2 Switch on both computers.
- 3.3 Take note of the operating system, which is used on each computer.
- 3.4 Establish the network identity or the computer name of each computer.
- 3.5 Using a hub or a cross-over cable, connect both computers together.
- 3.6 Using the appropriate command, identify and take a note of the Internet Protocol (IP) address of each computer.
- 3.7 Using the ping command, ping the other computer and write down the response.
- 3.8 Either select appropriate software provided by your instructor, or perform a search and download from the Internet a software tool that performs protocol analysis.
- 3.9 Correctly install the software on both computers.
- 3.10 Configure the protocol analysing software to capture Transmission Control Protocol (TCP)/IP activity.
- 3.11 Produce a monitoring activity report.
- 3.12 Install the firewall software provided by your instructor. Alternatively perform an Internet search, download and install a software tool that facilitates the implementation of firewall security.
- 3.13 Configure the firewall so that access to the other computer is blocked.
- 3.14 Using the ping command or any other network software, validate that the other computer cannot be accessed.
- 3.15 Produce a printout of the message telling you that access is not possible.
- 3.16 Hand your printouts in to your instructor.

4 Marking

- 4.1 Assignment completed in three hours. ()
- 4.2 Computers switched on. []
- 4.3 Operating systems of both computers recorded. ()
- 4.4 Network identity or computer name recorded. []
- 4.5 Computers connected together with a hub or cross-over cable. []
- 4.6 Correct IP address of both computers recorded. ()
- 4.7 Computers successfully pinged and response recorded. []
- 4.8 Appropriate protocol analysis software selected or downloaded. []
- 4.9 Protocol analysis software correctly installed on both computers. []
- 4.10 TCP/IP activity captured. []
- 4.11 Monitoring activity report produced. []
- 4.12 Firewall software installed. []
- 4.13 Firewall software correctly configured. []
- 4.14 Access to other computer successfully blocked. []
- 4.15 Printout of error message produced. ()
- 4.16 Printouts handed in to the instructor. []

5 Assignment completion

The candidate will have satisfactorily completed this assignment if successful in all items marked with a [] and at least two of the items marked with a ().

A period of seven days must elapse before an unsuccessful candidate may retake this assignment.

016 Radio systems

Introduction

The aim of this unit is to enable the candidate to

- a describe the basic principles and concepts involved in the antenna systems used for radio communication
- b describe the properties and applications of antenna systems
- c appreciate the factors that effect the propagation of radio signals
- d explain the operational characteristics of radio transmitters and receivers
- e describe the properties and applications of mobile telecommunication systems
- f appreciate the properties and characteristics of satellite systems.

Notes:

- 1 It is suggested that about 120 guided learning hours should be given to this unit.
- 2 It is recommended that the guided learning hours should be allocated as follows:

Fundamentals of electromagnetic radiation	7 hours
Antennas and feeder systems	12 hours
Radio Propagation	8 hours
Radio transmitters	20 hours
Radio receivers	24 hours
Mobile telecommunication systems	37 hours
Satellites	9 hours

Book list

Radio Systems Technology; D.C. Green.
The Essential Guide to Telecommunications; Annabel Dodd.
Wireless: The Revolution in Personal Telecommunications;
Ira Brodsky.

Practical competences

The candidate must be able to do the following:

- 1.1 Investigate the factors to be taken into account when planning a mobile network.
- 1.2 Provide a valid realistic solution to a problem involving the planning of a mobile network.

Knowledge requirements

The instructor must ensure the candidate is able to:

Fundamentals of electromagnetic radiation

- 1.3 Describe an electromagnetic wave in terms of its electric and magnetic field components and direction of propagation.
- 1.4 Explain that the velocity of an electro-magnetic wave in free space is approximately 3×10^8 m/s.
- 1.5 Define wavelength; state and use the relationship between velocity of propagation, frequency and wavelength.
- 1.6 Define wave polarisation.
- 1.7 Explain that the conditions for propagation of an electromagnetic wave are satisfied by the field pattern in a capacitor energised at high frequency.
- 1.8 Describe how radiation from a resonant LC circuit is increased by opening out the capacitor plates.
- 1.9 Explain that a straight wire provides the reactive elements of a LC circuit.
- 1.10 Explain that a straight wire of length l behaves as a LC circuit that resonates at a frequency corresponding to a wavelength $2l$ and thus as a $\lambda/2$ dipole.

Antennas (aerials) and feeder systems

- 1.11 Explain what is meant by the radiation pattern of an antenna.
- 1.12 Define directivity and side-lobe level of an antenna.
- 1.13 Describe the effect on the radiation pattern of adding a director and a reflector to a $\lambda/2$ dipole.
- 1.14 Explain the meaning and importance of the driving point impedance of a simple antenna.
- 1.15 Describe the increase of driving point impedance and bandwidth obtained by using a folded dipole.
- 1.16 Describe the effect of top capacitance of vertical aerials on the distribution of ground and space wave energy.
- 1.17 Distinguish between standing-wave and travelling-wave antennas and compare their bandwidth characteristics.
- 1.18 Describe the construction and radiation pattern of a rhombic antenna.
- 1.19 Describe the influence of incident wave polarisation on the performance of simple receiving antennas.

- 1.20 Describe, from consideration of electric and magnetic fields, the polarisation and radiation patterns in both planes of a $\lambda/2$ dipole.
- 1.21 Explain that radiation fields will produce electron movement in a conductor.
- 1.22 Explain why a receiving antenna should be tuned to, and have the polarisation of, the incident radiation.
- 1.23 Describe how a vertical $\lambda/4$ conductor earthed at its foot (a unipole) uses its image to behave as a $\lambda/2$ dipole.
- 1.24 Explain why a counterpoise is used when earthing is poor.
- 1.25 Describe simple methods of tuning a unipole.
- 1.26 Describe in simple terms how inverted L and T antennas improve radiation.
- 1.27 Describe the reception properties of a simple loop antennas from consideration of the field components of the incident wave.
- 1.28 Describe the principle of the ferrite rod antenna used in receivers.
- 1.29 Distinguish between balanced and unbalanced antenna feeders.
- 1.30 Describe the transmission and reception consequences of line loss and feeder mismatch at the antenna.
- 1.31 Describe methods of connecting balanced and unbalanced feeders to a transmitter output circuit.
- 1.32 Describe a method of matching a coaxial cable to a $\lambda/2$ antenna.
- 1.33 Explain the limitations of coaxial feeders and open-wire lines for use with high power transmitters.

Radio propagation

- 1.34 Explain the bandwidth requirements for telegraphy, facsimile, Double-SideBand (DSB) telephony and Single-SideBand (SSB) telephony, high quality sound broadcast and colour television.
- 1.35 Describe the frequency band definitions of very low frequency (v.l.f.), low frequency (l.f.), medium frequency (m.f.), high frequency (h.f.), very high frequency (v.h.f.), ultra high frequency (u.h.f.), super high frequency (s.h.f.) and extra high frequency (e.h.f.) using frequency and wavelength classifications.
- 1.36 Describe ground wave and sky wave propagation.
- 1.37 Distinguish between attainable propagation ranges at frequencies above and below 30 MHz.

- 1.38 Describe horizon limitation at frequencies above 30 MHz.
- 1.39 Calculate the approximate range of space wave propagated signals under normal atmospheric conditions using the formula:
 $dt = 4 \sqrt{ht}$
 where: dt = distance from the transmitting antenna in km, and
 ht = height (in metres) of the transmitting antenna above ground
- 1.40 Calculate the approximate maximum range for effective communication using space wave propagated signals under normal atmospheric conditions using the formula:
 $d = 4 \sqrt{ht} + 4 \sqrt{hr}$
 where: d = total distance between the transmitting and receiving antennae in km,
 ht = height (in metres) of the transmitting antenna above ground, and
 hr = height (in metres) of the receiving antenna above ground.
- 1.41 Describe the causes of fading in long range communication.
- 1.42 Distinguish between ionospheric, tropospheric, space and ground wave propagation.
- 1.43 Describe propagation ranges and bandwidth limitations for each mode of propagation.
- 1.44 Describe a typical service for each mode of propagation.

Radio transmitters

- 1.45 Explain the need for carrier frequency stability.
- 1.46 List the main causes of drift in LC oscillators.
- 1.47 Explain that a quartz crystal can behave as a highly stable LC circuit having a resonant frequency that depends upon crystal thickness.
- 1.48 Describe a simple crystal oscillator circuit.
- 1.49 Explain the reasons for including an r.f. amplifier stage in a transmitter.
- 1.50 Describe why modulation, or keying, is not carried out at the master oscillator stage.
- 1.51 Sketch and describe the block diagram of a simple Continuous Wave (CW) transmitter.
- 1.52 Sketch and describe the block diagram of a simple AM transmitter.
- 1.53 Sketch and describe the block diagram of a simple FM transmitter.

- 1.54 Describe simple methods of connecting a transmitter to a dipole or unipole antenna.
- 1.55 Explain the consequences of failing to match the transmitter output stage to its load.
- 1.56 Derive expressions for the spectral components of a sinusoidal carrier, amplitude modulated by a sinusoidal tone.
- 1.57 Calculate the power distribution between the spectral components of the AM wave in 1.56.
- 1.58 Explain that, in amplitude modulation, the signal information is completely provided by the carrier and one sideband.
- 1.59 Explain how signal information may be recovered at the receiver in a Single SideBand (SSB) system.
- 1.60 Compare SSB. and DSB systems in terms of power and bandwidth.
- 1.61 Describe, by means of block diagrams, the stages of an amplitude modulated transmitter.
- 1.62 Describe, using simplified circuit diagrams, the typical frequency control, modulator, driver and output amplifier stages of an amplitude modulated transmitter.
- 1.63 Use block diagrams to distinguish between high-level and low-level modulation.
- 1.64 Sketch simplified circuits of high-level and low-level modulation arrangements for class B and class C radio frequency (r.f.) output stages.
- 1.65 Calculate the modulator output power required for amplitude modulation of an r.f. stage to a specified modulation depth and a specified efficiency of the r.f. stage.
- 1.66 Describe the distribution of side frequency components in the spectrum of a sinusoidal carrier, frequency modulated by a sinusoidal tone.
- 1.67 Define and apply the terms modulation index (mf), maximum deviation or rated system deviation (fmax) and deviation ratio used in frequency modulation.
- 1.68 Explain the effects on the frequency spectrum of an FM wave as the following parameters of the modulating tone are increased.
Parameters: frequency, amplitude
- 1.69 Explain that a bandwidth of approximately $2(f_d + f_m)$ is sufficient for satisfactory communication in an FM system which has a deviation of f_d and is modulated by a baseband of maximum frequency f_m .
- 1.70 Explain why frequency-modulated services require carrier frequencies in excess of 50 MHz.
- 1.71 Describe in outline the reactance modulator and 'varactor' methods of varying oscillator frequency.
- 1.72 Describe in outline the indirect (Armstrong) method of frequency modulation of a carrier wave.
- 1.73 Explain the principle of frequency multiplication and its effect on frequency deviation.
- 1.74 Describe, using block diagrams, the function of each stage of a frequency-modulated transmitter.
- Radio receivers**
- 1.75 Describe the use of a parallel resonant circuit to provide selectivity.
- 1.76 Describe the process of demodulating an AM wave by means of a diode.
- 1.77 Explain why the demodulating diode is ineffective if the r.f. input to it is small, and hence state the need for r.f. amplification.
- 1.78 Describe in simple terms how an active device (black box treatment) is used to provide r.f. amplification of a received signal.
- 1.79 Describe in simple terms how an active device (black box treatment) is used to provide a.f. amplification after demodulation.
- 1.80 Sketch and describe the block diagram of a Tuned Radio Frequency (TRF) receiver.
- 1.81 Explain that when two r.f. carriers, having different frequencies, are present at the input of a device having a square-law characteristic then the output signal will include frequency components that are the sum and difference of those at the input.
- 1.82 Explain that when carrier waves having different frequencies are multiplied together they yield sum and difference frequencies.
- 1.83 Describe the process of heterodyning as a means of producing an a.f. tone from two r.f. carriers.
- 1.84 Describe the use of heterodyning in the reception of CW.
- 1.85 Describe in outline the method of obtaining a fixed intermediate frequency (i.f.) in a superheterodyne receiver.
- 1.86 Explain the main advantage of carrying out amplification at a fixed frequency prior to demodulation.

- 1.87 Calculate, for a particular value of i.f., the local oscillator range to cover a specified r.f. band.
- 1.88 Define image frequency and adjacent channel interference.
- 1.89 Explain why the level of second channel interference depends upon the selectivity of the input r.f. stage and the choice of intermediate frequency.
- 1.90 Describe the response requirements of the r.f. amplifier of a superheterodyne receiver.
- 1.91 Identify and describe the block diagram of a single superheterodyne receiver which is capable of receiving CW and AM signals.
- 1.92 Describe, with the aid of a block diagram, a two-way radio communication system which employs hybrid transformers to convert from 2-wire to 4-wire working.
- 1.93 Explain the importance of gain and signal/noise ratio in receiver performance.
- 1.94 Explain reasons for the presence of noise power at the receiver input.
- 1.95 Explain that the signal/noise ratio at the receiver input determines whether signal information can be identified.
- 1.96 Express signal power and noise power levels in dBm.
- 1.97 Express power gain, attenuation and signal/noise ratio in dB.
- 1.98 Describe the choice of intermediate frequency for m.f., h.f. and v.h.f.. single superheterodyne receivers.
- 1.99 Describe the i.f. bandwidth requirement for different types of AM service.
- 1.100 Calculate the image frequency and explain how second channel interference is minimised.
- 1.101 Explain the principles and purpose of simple and delayed automatic gain control.
- 1.102 Describe the principle of and a typical circuit for, a frequency mixer.
- 1.103 Describe, using block diagrams, the stages of an AM communication receiver.
- 1.104 Describe oscillator tracking error.
- 1.105 Describe three-point tracking with the aid of a circuit diagram of a mixer stage.
- 1.106 Define sensitivity, adjacent channel selectivity, image rejection ratio and output signal/noise ratio for a superheterodyne receiver.
- 1.107 Explain the principles of operation of frequency-modulated superheterodyne radio receivers.
- 1.108 Explain the purpose of a frequency discriminator.
- 1.109 Explain the consequence of non-linearity in discriminator response.
- 1.110 Explain, with the aid of sketches, the operation of typical frequency discriminator circuits.
- 1.111 Describe, with the aid of a block diagram, the stages of a FM receiver.
- 1.112 Account for the i.f. bandwidth requirement of an FM receiver.
- 1.113 Explain the consequences on a receiver output signal of reducing i.f. bandwidth.
- 1.114 Explain what is meant by 'capture effect' in FM reception.
- Mobile telecommunication systems**
- 1.115 Describe the basic principles and concepts involved in mobile telecommunication systems.
- 1.116 Describe the properties and applications of mobile telecommunication systems.
- 1.117 Investigate the range of mobile telecommunication systems available. Access sources of reference.
- 1.118 Distinguish between the differing environments of private and public mobile telecommunications systems in terms of their applications and user groups.
- 1.119 Explain why there was a major shift in the 1990s towards greater standardisation in mobile telecommunication.
- 1.120 State the frequency bands designated for use in Private Mobile Radio (PMR) and Public Land Mobile Network (PLMN) systems and give reasons why these bands are used.
- 1.121 With the aid of a diagram, show that in a cellular radio system the coverage area is divided into a number of linked cells, each with a base station.
- 1.122 Describe the concept of frequency re-use in cellular systems.
- 1.123 Explain that in conventional Frequency Division Duplex (FDD) systems, separate frequency bands are used for the uplink and downlink transmissions.

- 1.124 State the advantages associated with the use of digital rather than analogue signal processing techniques in telecommunications.
- 1.125 Describe the use of Time Division Multiple Access (TDMA) in modern mobile telecommunications systems.
- 1.126 Describe the problems associated with multiple path propagation in mobile telecommunications systems and describe the techniques used to combat those effects.
- 1.127 Explain why there is a need for error protection over the mobile air interface and state typical examples of schemes used.
- 1.128 Explain why there is a requirement for encryption over the air interface in mobile telecommunication systems.
- 1.129 Explain that PMR systems can be designed to provide local, regional or national coverage, depending on their application.
- 1.130 State that Terrestrial Trunked Radio (TETRA), is the first digital standard for PMR and Public Access Mobile Radio (PAMR) systems, developed by the European Telecommunications Standards Institute (ETSI).
- 1.131 Describe the basic TETRA system components, interfaces and operation.
- 1.132 Explain why the Global System for Mobile telecommunications (GSM) is the most popular standard in the world for second Generation (2G) PLMN systems.
- 1.133 Draw the block diagram of a generic PLMN identifying the following components and their main functionality: Mobile Station (MS), Base Transceiver Station (BTS), Base Station Controller (BSC), Mobile Switching Centre (MSC), Home Location Register (HLR), Visitor Location Register (VLR), Authentication Centre (AUC), Equipment Identity Register (EIR).
- 1.134 Describe the concept of 'mobility management' in a PLMN.
- 1.135 Explain that a cellular telephone regularly identifies itself to the nearest base station, whether or not a call is in progress.
- 1.136 State the possible reasons for a handover taking place in a PLMN.
- 1.137 Describe the main factors that determine cell size in a PLMN.
- 1.138 Describe how cell splitting and/or sectorisation can increase cell capacity.
- 1.139 State the inherent limitations of second generation PLMN data services.
- 1.140 Explain why packet switching techniques are more efficient than circuit switching for most mobile data applications.
- 1.141 Describe how time slot combination schemes such as the General Packet Radio Service (GPRS), can be used to provide higher data rates to users in TDMA systems.
- 1.142 Describe Enhanced Data rates for GSM Evolution (EDGE), as a modification to the GSM air interface modulation scheme in order to facilitate higher data rates.
- 1.143 State the implications for the introduction of EDGE into existing GSM networks.
- 1.144 Describe the Third Generation (3G) standardisation process and the main organisations involved.
- 1.145 State the proposed 3G air interfaces and the implications for global roaming.

Satellites

- 1.146 Describe the range of useful applications for satellites.
Applications: communications (point-to-point, military and mobile), data communication, meteorological/weather, geophysical survey, surveillance (spy), navigational aids, television (and radio) broadcasting
- 1.147 Describe the classes of orbits used by satellites and their characteristics.
Orbits: elliptical, low earth, polar circular, geostationary.
- 1.148 Explain the advantages and disadvantages of the geostationary orbit.
Advantages: always in view (one satellite is able to communicate with 42% of the earth's surface), three satellites are able to cover the entire globe (excepting the polar regions), there is no need for complicated tracking systems as the satellite remains virtually fixed above a given point on the equator, there are no breaks in transmission.
Disadvantages: the received signal strength is very weak (because of the large distances involved), propagation delay is considerable, more complex launch vehicles required, affected by earth and lunar eclipses, no coverage of the polar regions
- 1.149 State the distance in km above the equator for a satellite in a geostationary orbit.
- 1.150 Describe how satellites are placed into a geostationary orbit discuss the range of launch vehicles available.
- 1.151 Calculate the minimum propagation delay for communication with a geostationary satellite.
- 1.152 Describe the sources of noise which are likely to effect communication via a satellite in a geostationary orbit.

- 1.153 Explain what is meant by the term frequency re-use and how it may be achieved for satellite communications.
- 1.154 Describe the range of equipment on board a satellite in a geostationary orbit.
- 1.155 Explain how the communications facilities may be accessed.
- 1.156 Explain how severe weather conditions are likely to affect communications links via geostationary satellites.

Assessment

Test specification for written paper Radio Systems (2730-02-016)

This is a written examination paper lasting three hours with ten questions. Candidates must answer **all** questions.

The examination paper will cover the knowledge specifications:

Topic	Approximate % examination weighting
Fundamentals of electromagnetic radiation	5
Antennas and feeder systems	14
Radio propagation	8
Radio transmitters	20
Radio receivers	25
Mobile telecommunication systems	20
Satellites	8

Practical assignments – Radio Systems Practice

Practical assignment 017/1: Planning a Global System for Mobile Communication (GSM) network

1 Objective references

2730-02-016: 1.1 and 1.2

2 Preparation

2.1 Location of the test

The training centre or other venue where supervision and appropriate working conditions will be provided.

2.2 Requirements

Writing and drawing materials.

Copy of section 6 (scenario).

2.3 Instructor Notes

The aim of this assignment is to test the candidate's knowledge and understanding of cellular planning principles and the propagation characteristics of radio waves in the ultra high frequency (u.h.f.) band.

The time allowed for this assignment is three hours, not including the time needed to write up the report.

Instructors are encouraged to adapt the scenario in section 6.1, in order to make it relevant to their own region. Maps of the region would enhance the originality of the assignment and produce a more realistic response from the candidates. If this option is taken the candidate's instructions will need to be adapted.

3 Candidates' instructions

- 3.1 The time allowed for this assignment is three hours, not including the time needed to write up your report. Study carefully the scenario which you have been given by your instructor. Ensure that you understand all the requirements of the assignment and follow them precisely. If you are in any doubt ask your instructor.
- 3.2 Your task is to plan a Global System for Mobile Communication (GSM) network, to provide optimum GSM coverage in the cities of Northbank and Southbank, identified on the map. Your detailed plan should include:
 - 3.2.1 The number of cells required to meet coverage requirements.
 - 3.2.2 When determining 3.2.1, consideration must be given to the geography, population density, business concentration, frequency re-use (including cluster size and re-use distance) and allowance of control channels.
 - 3.2.3 Indicate your chosen transmission plan to link the cells to the Base Station Controllers (BSCs) and Mobile Switching Centres (MSCs), and your chosen transmission medium (taking into account the geography, particularly the river and other major transport routes). The Public Switched Telecommunications Network (PSTN) and associated transmission architecture is located in Southbank.
 - 3.2.4 The locations and optimum number of the BSCs and MSCs.
 - 3.2.5 Approximate height of the BSC antenna (use radio/radar range equation to estimate height).
 - 3.2.6 A diagram should be used to clearly illustrate your network architecture.
 - 3.2.7 Hand in the plan to your instructor.

4 Marking

- 4.1 Assignment completed within three hours (excluding write up) ()
- 4.2 Plan for optimum coverage provided including:
 - 4.2.1 Cell number provided. []
 - 4.2.2 Consideration given. ()
 - 4.2.3 Transmission plan indicated. []
 - 4.2.4 Locations and optimum numbers provided for BSCs and MSCs. []
 - 4.2.5 Approximate height of BSC antenna provided. ()
 - 4.2.6 Diagram clearly illustrates network architecture. []
 - 4.2.7 Plan handed in to the instructor. []

5 Assignment completion

The candidate will have satisfactorily completed this assignment if successful in all items marked with [] and at least two of the items marked with ().

A period of seven days must elapse before an unsuccessful candidate may retake this assignment.

6 Assignment documentation

- 6.1 SCENARIO relevant information

Geographical characteristics

The towns of Northbank and Southbank, both identified for coverage, lie on opposite banks of the River Knot, at its estuary. The river is 25 km wide at its estuary and 10 km wide at its narrowest point in this region. The river is a busy shipping lane serving the ferry port in Southbank and a small number of industries sited along the southern bank of the river in Southbank. Large deposits of silt and the susceptibility to tidal fluctuations necessitates the need for regular dredging.

Southbank, to the south of the River Knot, has a thriving business district and is densely populated with most people living and working in high-rise blocks, particularly along the river's edge. The M66 motorway, which skirts the southern edge of Southbank, is the main access link to Southbank. Northbank however, is a relatively sparsely populated but sprawling commuter and holiday town, with a small number of housing estates and associated facilities.

Regulatory standards

Frequency band: 900 MHz

ARFCNs: 48

Planning constraints

Planning permission for masts is strictly limited to 15 metres.

The voice of environmental concern is growing louder in Northbank, so efforts to minimise the number of sites is of paramount importance.

Link budgets restrict the maximum range of the MS to 8 km.

Area coverage per cell is 52 km² for sectorised cells and 200 km² for omnidirectional cells.

Macro cell range = 1 – 35km, Micro cell range = 0.1 – 1km.

Required service

GOS: 2%

Traffic per user (busy hour): 0.03 Erlangs (Erlang B tables to be used).

Northbank statistics

Population density: 800/km² (80% mobile users).

Area: 252 km²

Control channels: 2 per 48 traffic channels.

Southbank statistics

Population density: 60,000/km² (80% mobile users)

Area: 22km²

Control channels: 3 per 48 traffic channels

Map of Northbank and Southbank

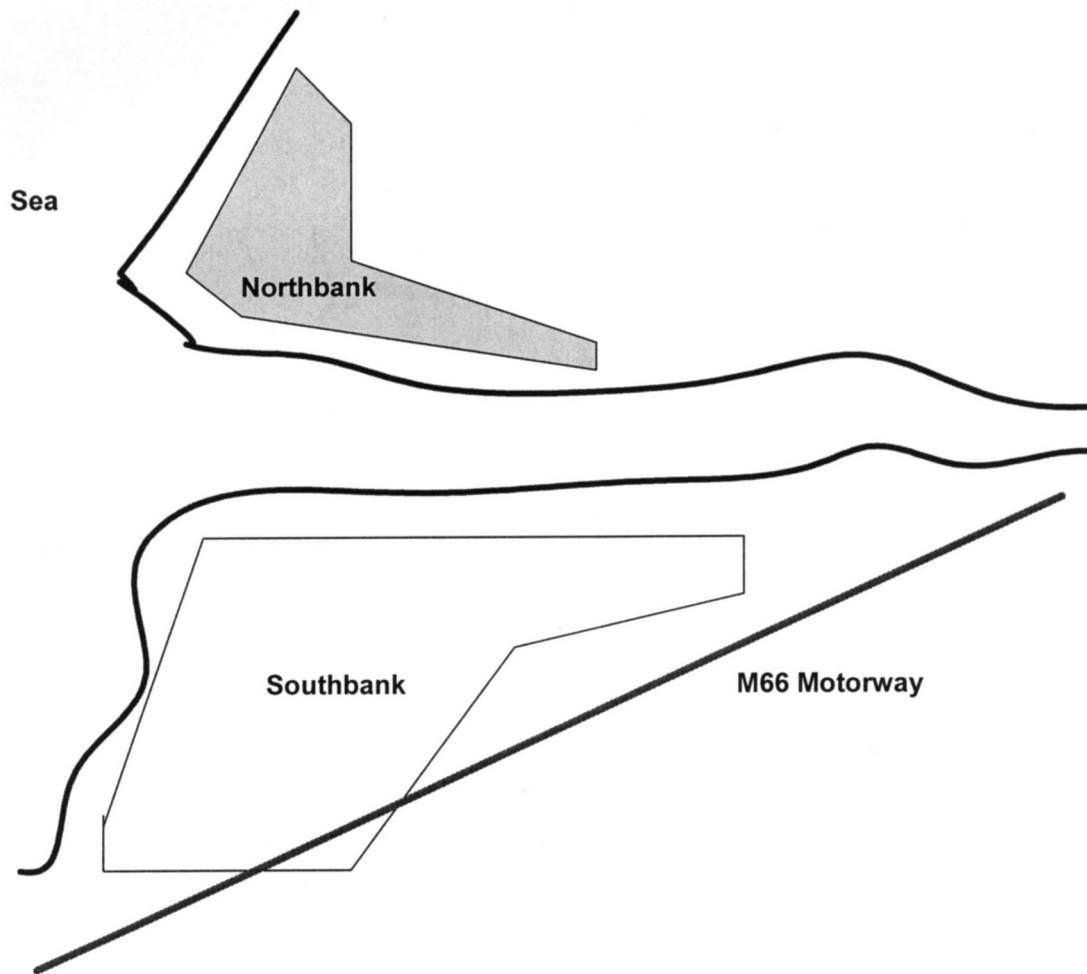

018 Programming Principles

Introduction

The aim of this unit is to enable the candidate to understand the

- a general concepts of programming languages
- b structures used within computer programs
- c information needed by programmers to produce software solutions.

Notes:

- 1 It is suggested that about 120 guided learning hours should be given to this unit.
- 2 It is recommended that the guided learning hours should be allocated as follows:

Basic knowledge	36 hours
Basic programming concepts	78 hours

Book list

The Formal Semantics of Programming Languages;
Glynn Winskel.

The Structure of Typed Programming Languages;
David A. Schmidt.

Practical competences

The candidate must be able to do the following:

- 1.1 Create a programme using pseudocode for given task.
- 1.2 Produce a flowchart and top down design for a given process.
- 1.3 Research and report on the chronological development of computer processor programming.
- 1.4 Identify reference sources of information.

Knowledge requirements

The instructor must ensure the candidate is able to:

Basic knowledge

- 1.5 Describe the main computer components crucial to program execution.
Components: disk storage, Random Access Memory (RAM), Central Processing Unit (CPU), Input/Output (I/O) devices
- 1.6 Describe the procedures involved for programs to be loaded, executed and discarded.
- 1.7 Describe the basic logical structures of a computer.

- 1.8 Discuss data handling by the CPU and the role of software to deal with data entities.
- 1.9 Explain the differences between machine code, low-level languages and high-level languages.
- 1.10 Give examples of machine code instructions.
Examples: peek, poke
- 1.11 Compare and contrast low-level languages.
Low-level languages: assembly language, machine code
- 1.12 Identify examples of code for a given low-level language.
- 1.13 Analyse program code for a small program and explain the command lines and their function.
- 1.14 List a number of high-level languages.
High-level languages: interpreted languages, basic
- 1.15 Identify examples of coding for a high-level language.
- 1.16 Obtain and analyse a program code for a high-level language.
- 1.17 Explain the importance that commenting plays in the programming process.
- 1.18 Explain the differences between compilers and interpreters.

Basic programming concepts

- 1.19 Identify data types, values and their representation.
Types: integers, real numbers (floating-point representation), character strings, Boolean operators
- 1.20 Describe how programming achieves basic arithmetic, logical and relational operations.
- 1.21 Describe basic program structures.
Structures: declaration, execution and termination
- 1.22 Explain basic program controls.
Controls: sequences, selections, repetitions
- 1.23 Describe the concepts and usage of subprograms.
Subprograms: functions, subroutines
- 1.24 Identify basic program design components.
Components: aims, programming methods, development stages, documentation
- 1.25 List the components of a program specification.
Components: reliability, maintainability, portability, readability, re-usability, efficiency, development time and costs
- 1.26 Explain detailed specifications.
Specifications: input, output, performance, security

- 1.27 Define the function and use of algorithms.
- 1.28 Draw a flowchart for a given process showing process boxes, decision boxes, input/output boxes, using a simple routine.
Routine: keyboard operation
- 1.29 Describe a top down design for a given process.
- 1.30 Discuss the differences, advantages and disadvantages of flowcharts and top down designs.
- 1.31 Describe the basic concepts of procedure programming.
- 1.32 Describe the basic concepts of object-oriented programming.
- 1.33 Explain a class.
Class: structure and behaviour of similar objects
- 1.34 Explain an object and its relation to class.
- 1.35 Describe the function of an object.
- 1.36 Explain objects and inheritance.
- 1.37 State the purpose of object encapsulation.
- 1.38 Describe the benefits of Object Orientated Programming (OOP) in relation to the usage of subprograms.
- 1.39 List programming languages and identify their levels.
- 1.40 Describe a low-level language in detail.
Low-level language: machine code, assembly
- 1.41 Describe a high-level language in detail.
High-level language: C, basic, VB, Java, Pascal, Cobol
- 1.42 Briefly explain databases, query languages and fourth Generation Languages (4GL).
- 1.43 Explain database definition types and their application.
- 1.44 Define Standard Query Language (SQL) and 4GL and their relations to relational database systems.
- 1.45 Identify display formats and explain the difference between display coding (tagging) and computer languages.
Coding: Standard Generalized Markup Language (SGML), Hyper Text Markup Language (HTML), Extensible Markup Language (XML)
- 1.46 Produce coding for a simple HTML Web page using a plain text editor ie without the use of software, which outputs as HTML.

Assessment

Test specification for written paper Programming Principles (2730-02-018)

This is a written examination paper lasting three hours with ten questions. Candidates must answer **all** questions.

The examination paper will cover the knowledge specifications:

Topic	Approximate % examination weighting
01 Basic knowledge	30
02 Basic programming concepts	70

Practical assignments – Programming Principals Practice

Practical assignment 019/1: Using pseudocode

1 Objective references

2730-02-018: 1.1 – 1.4

2 Preparation

2.1 Location of the test

The training centre or other venue where supervision and appropriate working conditions will be provided.

2.2 Requirements

Writing and drawing materials.

Access to reference materials.

2.3 Instructor notes

Part 1 and 2

The aim of part one and part two of this assignment is to demonstrate an ability to use pseudocode.

The time candidates are given for this task is three hours. All tasks should be completed within the allocated time.

Part 3

The aim of part three of this assignment is to demonstrate the ability to research and report findings on the chronological development of computer processor programming.

The time candidates are given for this task is three hours. The students will need to spend a considerable amount of their own time in researching part three of the assignment.

3 Candidates' instructions

- 3.1 The time allowed for parts one and two of this assignment is three hours. You are required to create pseudocode for a simple task and draw a flowchart showing the pseudocode procedure. You are advised to read the instructions carefully before commencing any work. Ensure that you understand all instructions and follow them precisely. If you are in any doubt ask the instructor.

The time allowed for part three of this assignment is three hours. You are required to research and create a report that relates to the chronological development of computer processor programming. The report for part three should be completed in your own time and handed in to your instructor before the given headline.

Part 1

- 3.2 Write a simple program using pseudocode. The program should

3.2.1 welcome the user, inform them of the task and instruct them how to proceed.

3.2.2 request three numbers from the user.
The first two numbers will become operands which will be added together.
The third number will represent their answer to the addition of the first two numbers.

3.2.3 If the answer is correct, the user should receive a greeting message read as 'Congratulation, you had the correct answer! Well done!'.

3.2.4 If the answer is incorrect, the user should receive a message 'Sorry, the answer was wrong. Please try again'.

Part 2

- 3.3 Draw a flow chart of the program using the following representations:

3.3.1 Output ('ABC') to display three characters ABC on the computer monitor.

3.3.2 Input (a) to get a number from the keyboard and store that number in a variable.

3.3.3 Use // to signify a comment line inside the program.

Part 3

- 3.4 Research and produce a report that relates to the chronological development of computer processor programming. The report should identify
 - 3.4.1 at least five major advancements in the area of computer programming and their significance
 - 3.4.2 the individuals or companies responsible for initiating and developing the advancements in 3.4.1
 - 3.4.3 the source of the reference material used to compile the report.
- 3.5 Hand your pseudocode programme, drawing and report in to your instructor.

4 Marking

- 4.1 All three parts of the assignment completed in the given time. ()

Part 1

- 4.2 Pseudocode written including:
 - 4.2.1 Welcoming the user, informing them of the task and instructing them how to proceed. []
 - 4.2.2 Requesting three numbers from the user. []
 - 4.2.3 If the answer is correct, the user receives the appropriate greeting message. []
 - 4.2.4 If the answer is incorrect, the user receives the appropriate greeting message. []

Part 2

- 4.3 Flowchart drawn using the following representations:
 - 4.3.1 Output ('ABC') displays three characters ABC on the computer monitor. ()
 - 4.3.2 Number input (a) from the keyboard and stored in a variable. ()
 - 4.3.3 // used to signify a comment line inside the program. ()

Part 3

- 4.4 Research carried out and report produced, which identifies
 - 4.4.1 five major advancements and their significance []
 - 4.4.2 those responsible for initiation and development of 3.4.1 []
 - 4.4.3 the source of reference material. ()
- 4.5 Pseudocode, drawing and report handed in to the instructor. []

5 Assignment completion

The candidate will have satisfactorily completed this assignment if successful in all items marked with a [] and at least two of the items marked with a ().

A period of seven days must elapse before an unsuccessful candidate may retake this assignment.

020 Advanced Mathematics 1

Introduction

The aim of this unit is to enable the candidate to

- advance and broaden the understanding of mathematics
- acquire additional mathematical knowledge (not mandatory) for application to the Diploma option units in the topic areas of radio systems and programming
- gain sufficient mathematical knowledge to proceed to the first year of a telecommunications or related degree course after successful completion of the Diploma.

Notes:

- The subjects in this unit would benefit if an integrative approach is used.
- Where possible, it is expected that worked examples will be selected to represent telecommunications, radio systems and programming problems.
- It is suggested that about 60 guided learning hours should be given to this unit.

Book list

Engineering Mathematics; L. Mustoe.

Knowledge requirements

The instructor must ensure the candidate is able to:

Quadratic functions

- Factorise quadratic expressions, including perfect squares and the difference of two squares.
- Solve quadratic equations with real roots by factorisation and by quadratic formula.
- Determine a quadratic equation from its two roots.
- Apply quadratic equations to practical problems such as linearly accelerated motion and second order chemical reactions.

Linear law fitting

- Identify dependent and independent variables.
- State the relation between two variables which are
 - directly proportional
 - inversely proportional.
- Calculate the proportionality constant from given data.
- State that, for inverse proportion, the product of variables is constant.

- Solve problems involving the laws of Hooke, Boyle, Charles and Ohm ($I \propto V$ and $I \propto 1/R$) and determine the proportionality constants.
- Identify coordinates from a set of experimental data which obeys a linear law, eg Hooke's law.
- Draw the best fit straight line by eye to fit the points.
- Determine the gradient of the straight line and state its physical meaning.
- Deduce the equation of the straight line using the gradient and the intercept.
- Determine the law of the straight line graph from the coordinates of two points on the line.
- Use the equation to calculate other values of the dependent variable.

Binomial expansion

- Expand $(a + b)^2$ and $(a + b)^3$
- Expand the general binomial expression $(a + b)^n$ for positive integral n .
- Identify the general form and signs of the binomial expansion terms, with their numerical coefficients (Pascal's triangle).
- Expand expressions of the form $(1 + x)^n$ for positive integral n .

Graphs

- Plot the graphs of $y = e^{\pm ax}$ with the aid of a calculator.
- Relate the graphs $y = ae^{bx}$ and $y = a(1 - e^{-bx})$, where a and b are positive, to communications technology applications.
- Use log-linear graph paper to plot straight line graphs for $y = e^{\pm x}$ and ae^{bx}
- Determine whether experimental results are related by laws of the type $y = ae^{bx}$ and $y = ax^n$ and estimate the constants from log-linear and log-log graphs.
- Define the gradient of any curve at a point as the gradient of the tangent at that point.

- 1.25 Determine the gradient of simple exponential growth and decay curves and verify that these gradients are proportional to the relevant ordinates.
- 1.26 Sketch, and explain the behaviour of, the graph of $\log_e x$

Complex numbers

- 1.27 Define a cartesian complex number as $z = x + jy$, where j is the square root of minus one.
- 1.28 Determine the sum, difference and product of two cartesian complex numbers.
- 1.29 Define modulus r and argument q for a polar complex number $z = r \angle q$
- 1.30 Represent complex quantities on an Argand diagram in both cartesian and polar forms.
- 1.31 Convert between cartesian and polar forms of a complex number.
- 1.32 Define the conjugate of a cartesian complex number, with its graphical representation.
- 1.33 Divide two different cartesian complex numbers by rationalisation of the denominator.
- 1.34 Evaluate expressions involving products and quotients of pairs of cartesian complex numbers.
- 1.35 Determine the modulus and argument of products and quotients of pairs of different polar complex numbers.
- 1.36 Solve equations containing both cartesian and polar complex numbers, including quadratic equations which produce complex roots.
- 1.37 Identify $\pm j$ and $\pm \sqrt{j}$ as rotators of phasors through angles of $\pm 90^\circ$ and $\pm 45^\circ$ respectively.
- 1.38 State that the most appropriate applications are cartesian for addition and subtraction, with polar for multiplication, reciprocal and division.

Trigonometry

- 1.39 Sketch a sine (and cosine) wave cycle using the vertical (and horizontal) projection of a rotating unit radius.
- 1.40 Determine values of the trigonometric ratios for angles between 0° and 360°
- 1.41 Define $\tan q$ as $\sin q / \cos q$ and sketch the graph of $\tan q$ for $0^\circ \leq q \leq 360^\circ$

- 1.42 Describe the periodic properties of the trigonometric functions.
- 1.43 Sketch graphs of $\sin nq$ and $\cos nq$ for $0^\circ \leq q \leq 360^\circ$
- 1.44 Deduce from the rotating radius construction that, for small values of q (rad)

- i $\sin q \approx q$
- ii $\cos q \approx 1$
- iii $\tan q \approx q$

- 1.45 State the compound angle formulae for $\sin(A \pm B)$ and $\cos(A \pm B)$
- 1.46 Deduce the double angle formulae for $\sin 2\theta$ and $\cos 2\theta$
- 1.47 Deduce that $\cos 2\theta = 2 \cos^2 \theta - 1$ or $1 - 2 \sin^2 \theta$
- 1.48 Sketch graphs of
- i $\sin^2 \theta$
 - ii $\cos^2 \theta$
- for one complete cycle.
- 1.49 Define angular velocity $\omega = 2\pi f$ rad s⁻¹ and deduce that the time period $T = 2\pi/\omega$
- 1.50 Determine the amplitude, frequency, time period and phase angle for the sinusoidal function expressed in the form $A \sin(\omega t + \phi)$
- 1.51 Show by calculation and graphical verification that the function of the type $A \sin(\omega t + \phi)$ is the sum of a sine term and a cosine term.
- 1.52 Express a function of the form $a \sin \omega t \pm b \cos \omega t$ in the form $A \sin(\omega t + \phi)$ and use this to solve problems.

Calculus

- 1.53 State that differentiation of a known function of a variable gives the gradient of the function.
- 1.54 Differentiate simple functions y such as k , ax , ax^2 from first principles.

- 1.55 Differentiate functions y of the form
- k (from first principles)
 - ax (from first principles)
 - ax^2 (from first principles)
 - ax^3 (using formula)
 - ax^n (using formula)
 - $a \sin bx$ (using formula)
 - $a \cos bx$ (using formula)
- 1.56 Recognise that the gradient is zero at a maximum or minimum point on a graph.
- 1.57 Obtain the second derivative of simple polynomial and trigonometric functions and use its sign to distinguish maxima, minima and points of inflexion.
- 1.58 Determine indefinite and definite integrals of the form $y = k, ax, ax^2, ax^3, ax^n$ ($n \neq -1$ and $n \neq -1$), $a \sin bx$ and $a \cos bx$
- 1.59 Define the mean, mean square and root mean square values of a function in a given interval.
- 1.60 Calculate the mean and root mean square values of sinusoidal functions between given limits using integration, with applications to mean power calculations using the $\cos 2q$ formulae.
- Permutations and combinations; probability**
- 1.61 Define the notation for the factorial of zero and any positive integer.
- 1.62 Deduce the formula $n! / (n - r)!$ for the number of permutations of r objects chosen from n unlike objects.
- 1.63 Deduce the formula $n! / (n - r)! r!$ for the number of combinations of r objects chosen from n unlike objects.
- 1.64 Perform simple calculations involving permutations and combinations.
- 1.65 Define probability p and complementary probability q and show that $p + q = 1$
- 1.66 Calculate the values of probability in simple cases.
- 1.67 Define mutually exclusive events, independent events and dependent events.
- 1.68 Perform calculations involving simple cases of total and compound probability.
- 1.69 Define the classical probability $P(A)$ of an event A occurring as (the number of ways A can occur) / (the total number of possible outcomes).
- 1.70 Solve simple problems using the multiplication and addition laws.
- 1.71 Determine the possible results of a total of 1, 2, 3 or 4 trials of a two-outcome event.
- 1.72 Verify that the number of successes (or failures) of a two-outcome event are given by successive terms in the expansion on $(1 + 1)^n$, where n is the number of trials in each case.
- 1.73 Verify that the probability values in a two-outcome event are the terms of $(\frac{1}{2} + \frac{1}{2})^n$, ie the terms of the binomial expansion of $(p + q)^n$, where $p = q = \frac{1}{2}$.
- 1.74 State that the general binomial probability distribution, ie the probability (P) of obtaining r successes in n trials (independent events) is
- $$P(r \text{ successes}) = \frac{n!}{(n-r)! r!} q^{n-r} p^r$$
- where, in any one trial, p is the probability of success and q is the probability of failure.
- 1.75 Construct a probability histogram and explain that the probability of a particular outcome is given by the area of the relevant column of the histogram.

Assessment

Test specification for written paper Advanced Mathematics 1 (2730-02-020)

This is a written examination paper lasting three hours with ten questions. Candidates must answer **all** question.

The examination paper will cover the knowledge specifications:

Topic	Approximate % examination weighting
Quadratic functions	5
Linear law fitting	15
Binomial expansion	5
Graphs	10
Complex numbers	15
Trigonometry	20
Calculus	10
Permutations and combinations; probability	20

Appendix A

Acronyms and abbreviations

2G	Second Generation	DPSK	Differential Phase Shift Keying
3G	Third Generation	DSB	Double-SideBand
AAL	ATM Adaption Layer	DSS	Digital Switching Subsystem
AAS	Automatic Announcement Subsystem	DSSS	Digital Subscriber Switching Subsystem
ABR	Automatic Bit Rate	DTE	Data Terminal Equipment
ACR	Attenuation-to-Crosstalk Ratio	DWDM	Dense Wavelength Division Multiplexing
ADM	Add and Drop Multiplexer	Eb/No	Energy of Bit-to-Noise Density Ratio
ADSL	Asymmetric Digital Subscribers Line	EDGE	Enhanced Data rates for GSM Evolution
a.f	audio frequency	EDH	European Digital Hierarchy
AM	Amplitude Modulation	EGP	Exterior Gateway Protocol
ANSI	American National Standards Institute	e.h.f	extra high frequency
APD	Avanlanche Photo Diode	EIR	Equipment Identity Register
ARQ	Automatic Repeat Request	EIRP	Effective Isotropic Radiated Power
AS	Autonomous System	ELFEXT	Equal Level Far End CrossTalk
ASBR	Autonomous System Boundary Routing	EMI	Electro Magnetic Interface OR Electro Magnetic Interference
ASCII	American Symbolic Code for Information Interchange	EPOS	Electronic Point Of Sale
ASLA	Application Service Level Agreement	ES	End Systems
ASP	Application Service Part	ETSI	European Telecommunications Standards Institute
ATM	Asynchronous Transfer Mode OR Automatic Teller Machine	F	noise Factor
AUC	Authentication Centre	FCS	Frame Check Sequence
BCD	Binary Coded Decimal	FD	Floor Distributor
BD	Building Distributor	FDD	Fequency Division Duplex
BER	Bit Error Rate	FDDI	Fibre Distributed Data Interface
BISUP	Broadband ISDN User Part	FEC	Forward Error Control
BJT	Bipolar Junction Transistors	FET	Field Effect Transistors
BMC	Broadcast / Multicast Control	FEXT	Far End Crosstalk
bps	bits per second	FM	Frequency Modulation
BSC	Base Station Controller	FSK	Frequency-Shift Keying
BT	Burst Tolerance	ftp	file transfer protocol
BTS	Base Transceiver Station	GFI	General Format Indicator
C/No	Carrier-to-Noise Density Ratio	GPR	General Packet Radio
CBR	Constant Bit Rate	GPS	Global Positioning Satellites
CCS	Common Channel Signalling	GSM	Global System for Mobile telecommunications
CD	Campus Distributor	GTP	GPRR Tunnelling Protocol
CDMA	Code Division Multiple Access	GUI	Graphical User Interface
CDMA-DS	Code Division Multiple Access – Direct Sequence	HDLC	High-level Data Link Control
CDV	Cell Delay Variation	h.f	high frequency
CGI	Common Gateway Interface	HLR	Home Location Register
CIDR	Classless Inter-Domain Routing	HTML	Hyper Text Markup Language
CLI	Call Line Identifiers	http	hyper text transfer protocol
CLR	Cell Loss Rate	HVAC	Heat Ventilation Air-Conditioning
CN	Core Network	ICMP	Internet Control Message Protocol
CPS	Call Processing Subsystem	ICT	Information and Communication Technology
CPU	Central Processing Unit	IDC	Internet Data Centre
CRC	Cyclic Redundancy Check	IEC	International Electrotechnical Comission
CS	Circuit Switched	IEEE	Institute of Electrical & Electronic Engineering
CSMA/CD	Carrier Sensing Multiple Access/Collision Detection	IETF	Internet Engineering Task Force
CTD	Cell Transfer Delay	i.f	intermediate frequency
CW	Continous Wave	IGP	Interior Gateway Protocol
DA	Destination Address	IMT-2000	International Mobile Telecommunications – 2000
dB	decibel	IN	Intelligent Networks
d.c	direct current	IP	Internet Protocol
DCE	Data Circuit-terminal Equipment	IPsec	Internet Protocol security
DHCP	Dynamic Host Configuration Protocol	IPv6	Internet Protocol version 6
DLT	Digital Line Termination	IPX	Internet Packet eXchange
DM	Delta Modulation	IS	Intermediate System
DNS	Domain Name Service	ISDN	Integrated Services Digital Network
DOD	Department Of Defence	ISI	Inter Symbol Interference

IS-IS	Intermediate-System to Intermediate-System	PHP	Perl Hypertext Pre-Processor
ISO	International Standards Organisation	PIN	P-type Intrinsic N-type
ISP	Internet Service Provider	PKI	Public Key Infrastructure
ITU	International Telecommunications Union	PLM	Public Land Mobile Landwork
JVM	Java Virtual Machine	PM	Phase Modulation
LAN	Local Area Network	PMR	Private Mobile Radio
LAP	Link Access Protocol	POTS	Plain Old Telephone System
LAPB	Link Access Procedure Balanced	PPM	Pulse Position Modulation
LAPD	Link Access Procedure on the D channel	PPP	Point-to-Point-Protocol
LAPF	Link Access Procedure for Frame relay	pps	packets per second
LAPM	Link Access Procedure for Modems	PS	Packet Switched
LCGN	Logical Channel Group Number	PSNEXT	Power Sun NEXT
LCN	Logical Channel Number	PSK	Phase-Shift Keying
LDN	Local Distribution Network	PSTN	Public Switched Telecommunications Network
LED	Light Emitting Diodes	PTI	Packet Type Identifier
l.f	low frequency	PTO	Public Telecommunications Operators
LLC	Logical Link Control	PUS	Processor Utility Subsystem
LNP	Local Number Portability	PVC	Permanent Virtual Circuit
LSA	Link State Advertisement	PWM	Pulse Width Modulation
MAC	Medium Access Control	QAM	Quadrature-Amplitude Modulation
MAN	Metropolitan Area Network	QoS	Quality of Service
MCS	Maintenance Control Subsystem	QPSK	Quadrature Phase Shift Keying
MDF	Main Distribution Frame	R99	Release 99
m.f	medium frequency	RAID	Redundant Array of Independent Drives
MIB	Management Information Base	RAKE	Radio Activated Key Entry
MMIS	Man Machine Interface Subsystem	RAM	Random Access Memory
MS	Mobile Station	r.f.	radio frequency
MSC	Mobile Switching Centre	RFC	Request For Comments
MSS	Management Statistics Subsystem	RFP	Request For Proposal
mtbf	mean-time-between-failures	RIP	Routing Information Protocol
MTP	Message Transfer Part	RLC	Radio Link Control
MTS	Message Transmission Subsystem	RMON	Remote Monitoring
mttr	mean time to repair	r.m.s	root mean square
NA	Numerical Aperture	ROADS	Running Out Of Address Space
NADH	North American Digital Hierarchy	RTO	Regional Telephone Operators
NAT	Network Address Translation	SA	Source Address
NEXT	Near End CrossTalk	SAP	Service Advertisement Protocol
NF	Noise Factor	SCCP	Signalling Connection Control Part
NIC	Network Interface Card	SCP	Service Control Point
NMS	Network Management System	SCR	Sustained Cell Rate
NSS	Network Synchronisation Subsystem	SDH	Synchronous Digital Hierarchy
NUA	Network User Address	SFD	Start Frame Delimiter
OOP	Object Oriented Programming	SGML	Standard Generalized Markup Language
op-amp	operational amplifiers	s.h.f	super high frequency
OSI	Open Systems Interconnection	SLA	Service Level Agreement OR Synchronous Line Adapter
OSIRM	Open Systems Interconnection Reference Model	SLD	Semiconductor Laser Diodes
OSPF	Open Shortest Path First	SMI	Structure of Management Information
OVSF	Orthogonal Variable Spreading Factor	sntp	simple mail transfer protocol
PABX	Private Automatic Branch Exchanges	SNMP	Simple Network Management Protocol
PAD	Packet Assembler / Disassembler	SONET	Synchronous Optical NETWORK
PAM	Pulse Amplitude Modulation	SPC	Stored Program Control
PAMR	Public Access Mobile Radio	SQL	Standard Query Language
PBX	Private Branch eXchange	SS7	Signalling System No. 7
PC	Personal Computer	SSB	Single-SideBand
PCM	Pulse Code Modulation	SSM	Solstice Sunnet Manager
PCR	Peak Cell Rate	SSP	Service Switching Point
PDCP	Packet Data Convergence Protocol	SSW	Space SWitch
PDH	Plesiochronous Digital Hierarchy	STA	Spanning Tree Algorithm
PDN	Public Data Network		

STM	Synchronous Transfer Mode	UML	Unified Modelling Language
STP	Shielded Twisted Pair OR Signal Transfer Point OR Spanning Tree Protocol	UMTS	Universal Mobile Telephone System
STS	Synchronous Transfer Signal	UPS	Uninterrupted Power Supply
SVC	Switched Virtual Circuit	UTP	Unshielded Twisted Pair
TCAP	Transaction Capabilities Application Part	UTRAN	UMTS Terrestrial Radio Access Network
TCP	Transmission Control Protocol	VBR	Variable Bit Rate
TCP/IP	Transmission Control Protocol/Internet Protocol	VCC	Virtual Channel Connection
TDM	Time Division Multiplexing	VCI	Virtual Channel Identifier
TDMA	Time Division Multiple Access	v.h.f	very high frequency
TETRA	Terrestrial Trunked Radio	VLAN	Virtual Local Area Network
TFTP	Trivial File Transfer Protocol	v.l.f	very low frequency
TNS	Test Network Subsystem	VLR	Visitor Location Register
TO	Telecommunication Outlet	VLSM	Variable Length Subnet Masks
TP	Transition Point	VOIP	Voice Over Internet Protocol
TRF	Tuned Radio Frequency	VPC	Virtual Path Connection
TSW	Time SWitch	VPI	Virtual Path Identifier
TTL	Time To Live	VPN	Virtual Private Network
TUP	Telephone User Part	VSAT	Very Small Aperture Satellite
UBR	Unspecified Bit Rate	WAN	Wide Area Network
UDP	User Datagram Protocol	WDM	Wavelength Division Multiplexing
u.h.f	ultra high frequency	xDSL	xDigital Subscriber Line
		XML	eXtensible Markup Language
		XOS	Cross Office Slot

[This page is intentionally blank]

Appendix B

Resource requirements

City & Guilds has identified a list of minimum requirements for the Technician Diploma in Telecommunication Systems. You should use this list to make sure that you have the necessary resources to offer the programme.

The visiting verifier should also use this list to check that all candidates have access to the resources needed to be successful. You do not have to provide all the resources in one location, for example you may have teaching rooms in one location and you may use a different location (such as a workshop and laboratories) to provide access to resources that are not in the teaching rooms.

This list is intended to be appropriate to a wide range of locations. For example, electronic component catalogues may come from Internet sources that originate from the local or worldwide market.

Diploma – resource list

Accommodation

- Teaching rooms, workshops and laboratories.
- Layout of premises to allow for good work flow.

Equipment and tools

- Scientific calculators
- Personal computers
- Ethernet network cards
- Ethernet hub or switch
- Category 5 cables with RJ45 connectors
- Printers
- Storage media
- Software applications
 - **Software:** word processing, database, spreadsheet, packet analyser/sniffer
 - Maps and local guide books
- Electronic components
 - Components: resistors, capacitors, inductors, transformers, electromagnetic relays, semiconductor diodes, transistors (bipolar and field-effect), integrated circuits (linear), logic gates (AND, OR, NAND, NOR, Exclusive OR), connectors
- Test equipment
 - **Equipment:** power supplies, ammeters, voltmeters, oscilloscopes, continuity testers, protocol analyser, network analyser, network simulator, optical power meters telephone instruments, modems, radio receivers (multiband), loudspeakers, microphones, television receivers,
- Communications media
 - **Media:** twin, multi-core/ multi-pair, ribbon cable, twisted pair (shielded and unshielded), coaxial cables, waveguide, optical fibres (mono-mode, multi-mode, graded-index); examples of structured cabling
- Electronic component catalogues
 - **Catalogues:** eg Farnell Electronic Components (<http://www.farnell.com/>), RS Components ([www1.rswww.com](http://www.rswww.com)), Combined Precision Components (<http://www.cpc.co.uk/>), Maplin electronics (www.maplin.co.uk)
 - Electronic component catalogues from (local) national or other international suppliers may be considered equivalent.
- Network component catalogues
 - **Catalogues:** eg Misco Networking (<http://www.misco.co.uk>), Cisco (<http://www.cisco.com>), Extreme Networks (<http://www.extremenetworks.com>)
 - Network component catalogues from (local) national or other international suppliers.
- Network reference sites:
 - <http://www.iec.org/online/tutorials/>,
 - <http://www.ietf.org/rfc.html>, <http://www.iso.org>,
 - <http://standards.ieee.org/>
- **Reference books:** See recommended reading list.

Appendix C

Practical assignments

Two assessment methods are used in the 2730 Technician Awards in Telecommunication Systems programme – written questions and practical assignments.

Practical assignments

Each unit or component in the diploma level of this programme has one or more related practical assignments. These assignments may call on skills covered in other sections but reference is only made to the objectives covered by the marking criteria. Wherever relevant, the option is given to you to use local names, local standards, alternative measures and paper sizes, or to design an alternative assignment. Where this option is taken **the assignment must be of a comparable standard** to ensure consistency between centres using this programme. The assignment must be documented and available to the visiting verifier. ALL assignments must be successfully completed.

The assignments may be administered at any time convenient to the instructor and to the candidate.

The practical assignments in this publication are intended to be photocopied.

Instructor notes

It is essential that you read these before attempting to administer the practical assignment. Practical assignments usually require you to prepare material for the assignment.

Candidate instructions

Make sure every candidate has a copy of these before beginning the practical assignment.

Marking

The marking is based on performance criteria or outcomes related to the practical assignment, to which the answer will always be either 'yes' – the candidate achieved this or 'no' – the candidate did not achieve this. Credit is given for those performance objectives for which the answer is 'yes' – the candidate achieved this.

Supervision

All assignments require supervision and you must make sure that the results reflect only the individual candidate's own work. You must keep all assessment documentation and material in a file for each candidate until the results have been agreed by the visiting verifier and until confirmation of the result has been received from City & Guilds.

Records, results and certification

Successful completion of the related practical assignments for each unit or component needs to be recorded and then sent to City & Guilds. We suggest that you keep a record of each individual's achievement that may then be transferred to the entry forms. A model is given at the end of this section but you may use any form of record keeping that is convenient and accessible.

In order to gain certification, results for successfully completed practical assignments must be sent to City & Guilds. Results for practical assignments are entered onto Form S that must be countersigned by the visiting verifier and sent to us.

An advantage of this programme is that candidates who successfully complete the practical assignments for a single unit or component may, if they wish, claim a certificate of unit credit. This may be beneficial for those candidates who only wish to complete part of this programme. Send these claims to us at any time provided the visiting verifier has countersigned the Form S.

Candidates wishing to gain the full award (certificate, diploma or advanced diploma) must successfully complete all forms of assessment. We recommend that the practical results are sent at the time of, or shortly before, the date of the written examinations.

Visiting verifier

The operation of this programme requires the appointment of a visiting verifier. **The visiting verifier must countersign the results of the practical assignments on Form S.** The visiting verifier should also be able to inspect records and candidates' work to verify the results before submission.

Technician Diploma in Telecommunication Systems Candidate assessment record

*Candidates must complete these assignments

Candidate's name and number

Centre name and number

Assessment reference	Date completed	Instructor signature	Instructor name
015/1 Boolean circuits and gates			
015/2 Impedance and decibels			
015/3 Data communication			
015/4 TCP/IP network address configuration			
015/5 Router configuration, TCP/IP and OSI layer models			
015/6 Modem design and characteristics			
015/7 Aspects of telephone networks			
015/8 Structured cabling			
015/9 Designing a LAN, MAN and WAN solution			
015/10 SONET			
015/11 Designing endsystems for a SME			
015/12 Network management tools			
017 Radio Systems Practice			
019 Programming Principles Practice			

Appendix D

The levels of our awards

Progressive structure

Achieving maximum potential

All City & Guilds qualifications are part of an integrated, progressive structure of awards arranged over seven levels, allowing people to progress from foundation to the highest level of professional competence. Senior awards, at levels 4 to 7, recognise outstanding achievement in industry, commerce and the public services. They offer a progressive vocational, rather than academic, route to professional qualifications. An indication of the different levels and their significance is given below.

City & Guilds level	Qualification/Programme	
7	Fellowship (FCGI)	The highest level of technological and managerial experience.
6	Membership (MCGI)	Professional or managerial status, at the level of Master's degree.
5	Graduateship (GCGI)/ Associateship (ACGI)*, NVQ5	Requires the ability to master and apply complex principles and techniques in a variety of contexts and to assume significant responsibility for human and plant resources, at the level of first degree.
4	Full Technological Diploma (FTD), Full Technological Certificate (FTC), Advanced Technician Diploma (IVQ), Licentiate (LCGI), NVQ4	Demands specialist or technical expertise and the ability to undertake professional work, at the level of Master Craftsman in Europe.
3	Technician Diploma (IVQ), Advanced Vocational Diploma (IVQ), Vocational (non NVQ/IVQ) Level 3 NVQ3	Denotes skilled work of a complex nature and the ability to undertake a supervisory role.
2	Technician Certificate (IVQ), Vocational Diploma (IVQ), Vocational (non NVQ/IVQ) Level 2, NVQ2	Recognises competence in a more demanding range of activities which require a degree of individual responsibility.
1	Vocational Certificate (IVQ), Vocational (non NVQ/IVQ) Level 1, NVQ1	Indicates the ability to perform basic or routine activities which provide the broad foundation for progression.

*Only graduates of the City & Guilds College, Imperial College of Science, Technology and Medicine, are awarded the Associateship (ACGI).

NVQ – National Vocational Qualifications

IVQ – International Vocational Qualifications

[This page is intentionally blank]

International Vocational Qualifications

IVQs currently available:

- 1100 Skills Certificate in Health and Safety
- 1104 International Certificate in Training Skills
- 1104 International Diploma in Teaching and Training
- 1105 International Assessor Award
- 1121 Retailing
- 1122 Awards in Hairdressing
- 1123 Awards in Beauty Therapy
- 1155 Awards in Engineering Skills
- 2565 Technician Awards in Engineering
- 2730 Technician Awards in Telecommunication Systems
- 3905 Motor Vehicle Engineering
- 4865 International Tourism
- 6161 Construction Industry
- 6165 Construction Industry Technician
- 7065/6/7/8 Hospitality & Catering (Revised Syllabus)
- 7235 Applied Information Technology
- 8030 (2000) Electrical and Electronic Engineering

[This page is intentionally blank]

Published by City & Guilds
1 Giltspur Street
London
EC1A 9DD
T +44 (0)20 7294 3505
F +44 (0)20 7294 2425
international@city-and-guilds.co.uk
www.cityandguilds.com

City & Guilds is a registered
charity established to promote
education and training